



FAST RECOVERY GLASS PASSIVATED RECTIFIER FR201G ~ FR207G

Fast Recovery Glass Passivated Rectifier

Features

- Fast switching speed for high efficiency
- Glass passivated chip junction
- Low reverse leakage
- High forward surge current capacity
- High temperature soldering guaranteed:
260°C/10 seconds, 0.375" (9.5mm) lead length
- RoHS and REACH Compliance

Mechanical Data

Case:	Transfer molded plastic
Polarity:	Color band denots cathode end
Epoxy:	UL94V-0 rate flame retardant
Lead:	Plated axial lead, solderable per MIL-STD-202E method 208C
Mounting position:	Any
Weight:	0.014 ounce, 0.39 gram

Maximum Ratings ($T_{Ambient}=25^{\circ}C$ unless noted otherwise)

Symbol	Description	FR201G	FR202G	FR203G	FR204G	FR205G	FR206G	FR207G	Unit	Conditions
VRRM	Max Recurrent Peak Reverse Voltage	50	100	200	400	600	800	1000	V	
VRMS	Max RMS Voltage	35	70	140	280	420	560	700	V	
VDC	Max DC Blocking Voltage	50	100	200	400	600	800	1000	V	
I(AV)	Max Average Forward Rectified Current	2.0							A	TC=55°C
IFSM	Peak Forward Surge Current	70							A	JEDEC method
TJ,TSTG	Operating and Storage Temperature Range	-65 to +175, -65 to +175							°C	
Rθ-JA	Typical Thermal Resistance	40							°C/W	Note 2

Electrical Characteristics ($T_{Ambient}=25^{\circ}C$ unless noted otherwise)

Symbol	Description	FR201G	FR202G	FR203G	FR204G	FR205G	FR206G	FR207G	Unit	Conditions
VF	Max Instantaneous Forward Voltage	1.3							V	2.0A
IR	Max DC Reverse Current at Rated DC Blocking Voltage	5.0							μA	TA=25°C
		500							mA	TA=125°C
TRR	Maximum reverse recovery time	150		250			500	nS	Note 1	
Cj	Typical Junction Capacitance	20							pF	Measured at 1.0MHz / 4.0V

Note:

1. Reverse recovery test conditions: $I_F=0.5A$, $I_R=1.0A$, $I_{RR}=0.25A$
2. Thermal resistance from junction to ambient with 0.375" (9.5mm) lead length, PCB mounted

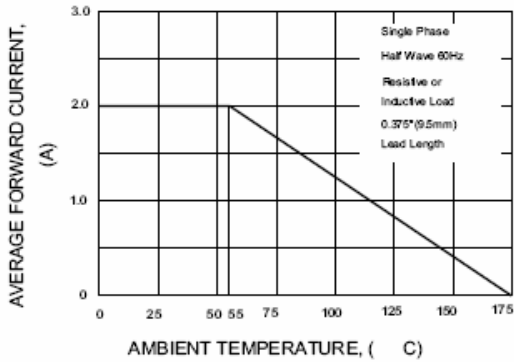
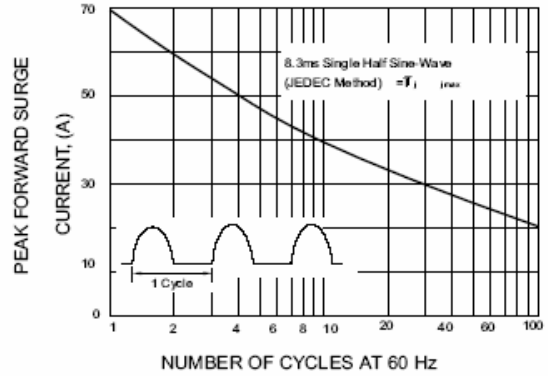
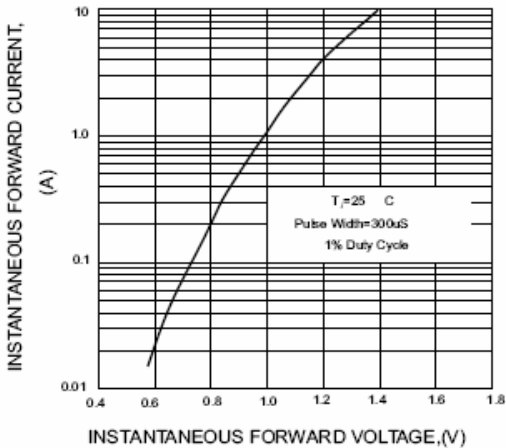
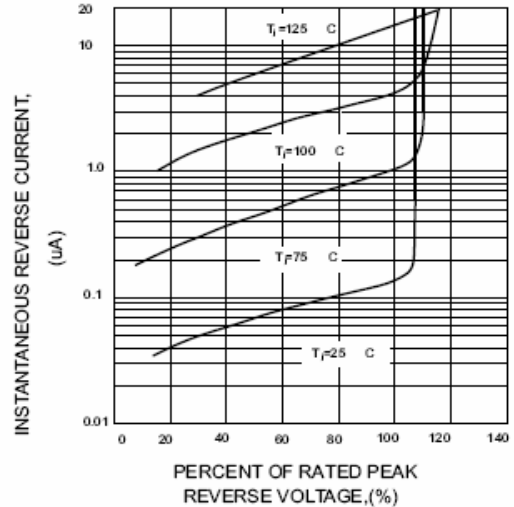
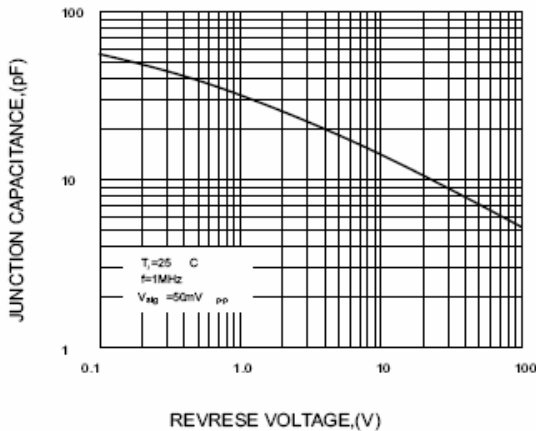
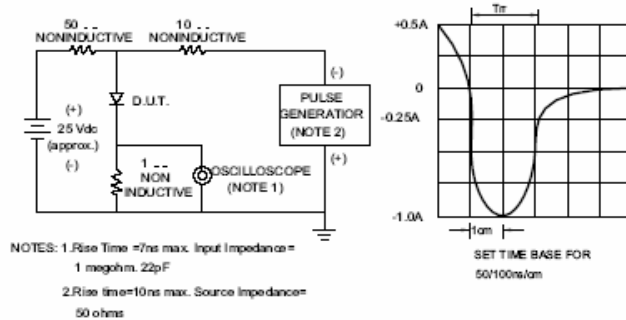
FR201G ~ FR207G
RATINGS AND CHARACTERISTIC CURVES FR201G THRU FR207G
FIG.1-TYPICAL FORWARD CURRENT DERATING CURVE

FIG.2-MAXIMUM NON-REPETITIVE PEAK FORWARD SURGE CURRENT

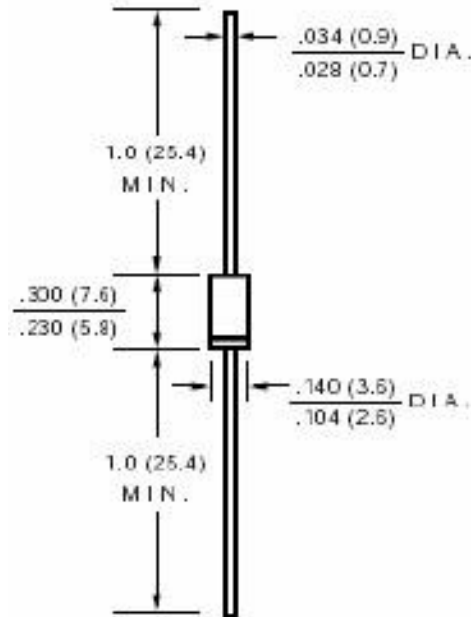
FIG.3-TYPICAL INSTANTANEOUS FORWARD CHARACTERISTICS

FIG.4-TYPICAL REVERSE CHARACTERISTICS

FIG.5-TYPICAL JUNCTION CAPACITANCE

FIG.6-TEST CIRCUIT DIAGRAM AND REVERSE RECOVERY TIME CHARACTERISTIC

Dimensions in inches (mm)



DO-15

Contact us:

US HEADQUARTERS

MEI SEMI INC.

2902 Corvin Drive, Santa Clara, CA95051, USA

Tel: 1-408-733-0808 Fax: 1-408-733-2828