



HIGH EFFICIENCY GLASS PASSIVATED RECTIFIER HER601G ~ HER608G

High Efficiency Glass Passivated Rectifier

Features

- Glass passivated chip junction
- Low power loss, high efficiency
- Low leakage
- High Surge Capacity
- High switching speed
- High temperature soldering guaranteed:
260°C/10 seconds, 0.375" (9.5mm) lead length
- RoHS and REACH Compliance

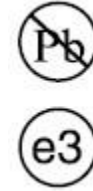

Mechanical Data

Case:	Transfer molded plastic
Polarity:	Color band denotes cathode end
Epoxy:	UL94V-0 rate flame retardant
Lead:	Plated axial lead, solderable per MIL-STD-202E Method 208C
Mounting Position:	Any
Weight:	0.07 ounce, 2.0 gram

Maximum Ratings ($T_{Ambient}=25^{\circ}C$ unless noted otherwise)

Symbol	Description	HER 601G	HER 602G	HER 603G	HER 604G	HER 605G	HER 606G	HER 607G	HER 608G	Unit	Conditions
VRRM	Max Recurrent Peak Reverse Voltage	50	100	200	300	400	600	800	1000	V	
VRMS	Max RMS Voltage	35	70	140	210	280	420	560	700	V	
VDC	Max DC Blocking Voltage	50	100	200	300	400	600	800	1000	V	
I(AV)	Max Average Forward Rectified Current 0.375" (9mm) lead length	6.0								A	TA=50°C
IFSM	Peak Forward Surge Current	200				150				A	JEDEC method
TJ,TSTG	Operating and Storage Temperature Range	-55 to +150, -55 to +150								°C	
Rθ-JA	Typical Thermal Resistance	20								°C/W	Note 2

Electrical Characteristics ($T_{Ambient}=25^{\circ}C$ unless noted otherwise)

Symbol	Description	HER 601G	HER 602G	HER 603G	HER 604G	HER 605G	HER 606G	HER 607G	HER 608G	Unit	Conditions	
VF	Max Instantaneous Forward Voltage	1.0		1.3		1.5		1.7		V	6.0A	
IR(AV)	Maximum Full Load Reverse Current, Full Cycle average	150									µA	0.375" (9.5mm) lead length at TL= 55°C
IR	Max DC Reverse Current at Rated DC Blocking Voltage	10									µA	TA=25°C
		500										TA=125°C
TRR	Maximum reverse recovery time	50				70				nS	Note 1	
CJ	Typical Junction capacitance	110									pF	Measured at 1.0MHz / 4.0V

Note:

1. Reverse recovery test conditions: $I_F=0.5A$, $I_R=1.0A$, $I_{RR}=0.25A$
2. Thermal resistance from junction to ambient with 0.375" (9.5mm) lead length, PCB mounted

HER601G ~ HER608G

RATINGS AND CHARACTERISTIC CURVES HER601G THRU HER608G

FIG.1-TYPICAL FORWARD CURRENT DERATING CURVE

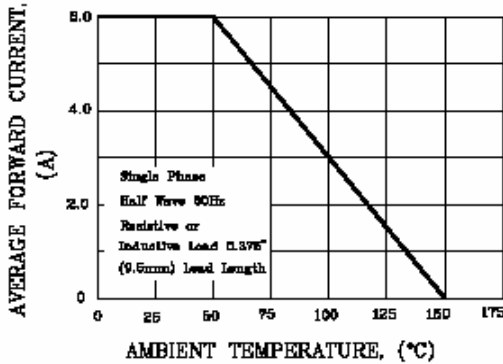

FIG.2-MAXIMUM NON-REPETITIVE PEAK FORWARD SURGE CURRENT

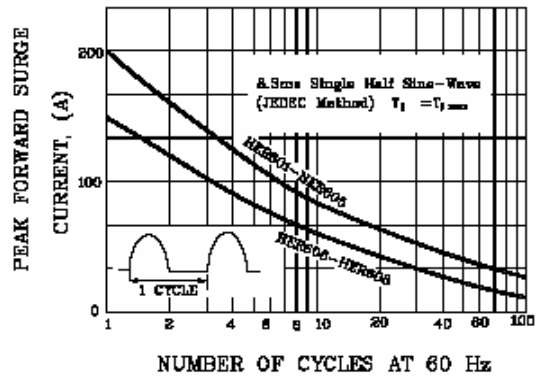

FIG.3-TYPICAL INSTANTANEOUS FORWARD CHARACTERISTICS

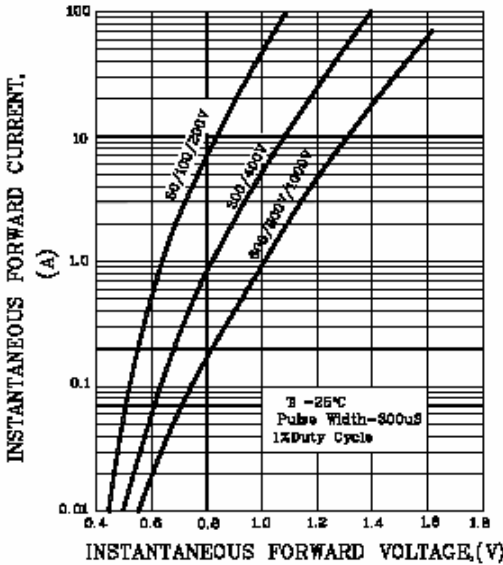

FIG.4-TYPICAL REVERSE CHARACTERISTICS

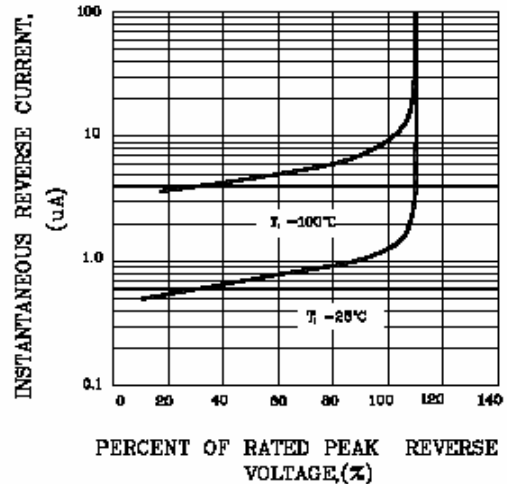

FIG.5-TYPICAL JUNCTION CAPACITANCE

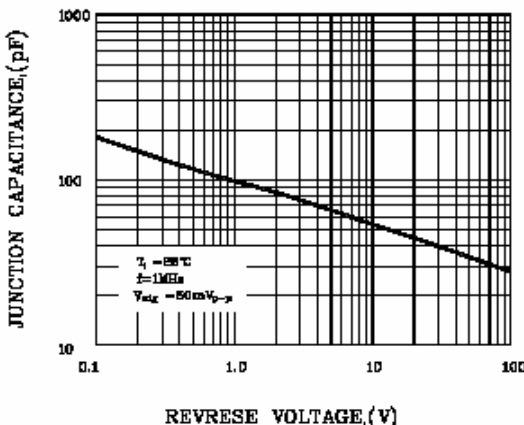
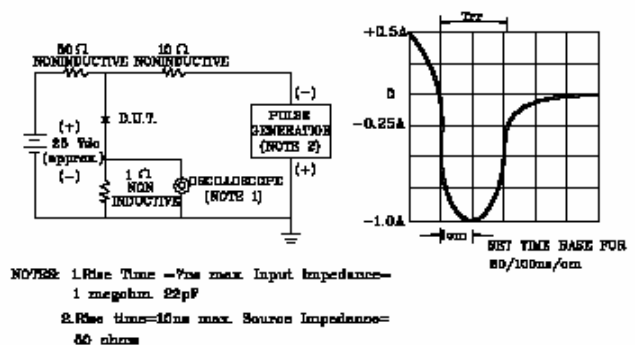
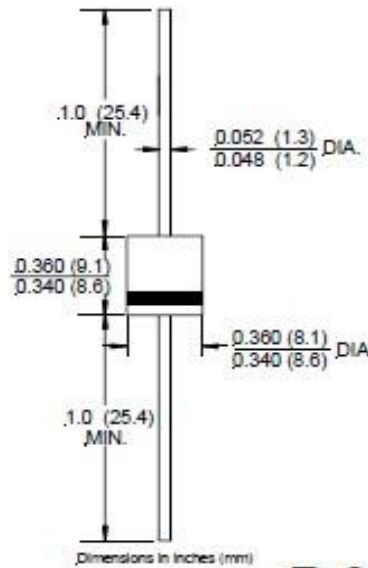

FIG.6-TEST CIRCUIT DIAGRAM AND REVERSE RECOVERY TIME CHARACTERISTIC



HER601G ~ HER608G

Dimensions in inches (mm)



R-6

Contact us:

US HEADQUARTERS

MEI SEMI INC.

2902 Corvin Drive, Santa Clara, CA95051, USA

Tel: 1-408-733-0808 Fax: 1-408-733-2828