



SURFACE MOUNT HIGH EFFICIENCY RECTIFIER US1AB ~ US1MB

Surface Mount High Efficiency Rectifier

Features

- Plastic package has Underwriters Laboratory Flammability Classification 94V-0
- Built-in strain relief, ideal for automated placement
- Fast switching speed for high efficiency
- Glass passivated chip junction
- High temperature soldering guaranteed:
260°C/10 seconds
- RoHS and REACH Compliance



DO-214AA (SMB)



RoHS
COMPLIANT

Mechanical Data

Case:	JEDEC DO-214AA molded plastic over glass passivated chip
Polarity:	Color band denotes cathode end.
Terminal:	Solder plated, solderable per MIL-STD 750, Method 2026
Mounting Position:	/
Weight:	0.003 ounce, 0.093 gram

Maximum Ratings ($T_{Ambient}=25^{\circ}C$ unless noted otherwise)

Symbol	Description	US1AB	US1BB	US1DB	US1GB	US1JB	US1KB	US1MB	Unit	Conditions
VRRM	Max Recurrent Peak Reverse Voltage	50	100	200	400	600	800	1000	V	
VRMS	Max RMS Voltage	35	70	140	280	420	560	700	V	
VDC	Max DC Blocking Voltage	50	100	200	400	600	800	1000	V	
I(AV)	Max Average Forward Rectified Current	1.0							A	TA=55°C
IFSM	Peak Forward Surge Current, 8.3ms single half sine	30							A	JEDEC method
TJ,TSTG	Operating and Storage Temperature Range	-55 to +150							°C	

Electrical Characteristics ($T_{Ambient}=25^{\circ}C$ unless noted otherwise)

Symbol	Description	US1AB	US1BB	US1DB	US1GB	US1JB	US1KB	US1MB	Unit	Conditions
VF	Max Instantaneous Forward Voltage	1.0		1.3		1.7			V	1.0A
Rθ-JA	Typical Thermal Resistance	88							°C/W	Note 2
Rθ-JL		28								
IR	Max DC Reverse Current at Rated DC Blocking Voltage	5							µA	TA=25°C
		100								TA=125°C
TRR	Maximum reverse recovery time	50			75				nS	Note 1
CJ	Typical Junction capacitance	20			15				pF	Measured at 1.0MHz/4.0V

Note:

1. Test conditions: $I_F=0.5A$, $I_R=1.0A$, $I_{RR}=0.25A$
2. Thermal resistance from junction to ambient and from junction to lead mounted on PCB with 0.2" x 0.2" (5.0x5.0mm) copper pad areas.

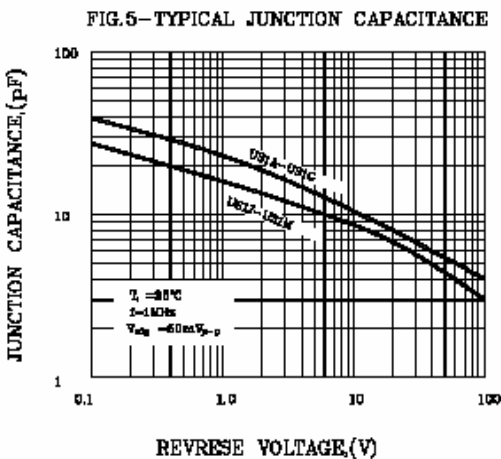
US1AB ~ US1MB
RATINGS AND CHARACTERISTIC CURVES US1A THRU US1M

FIG.6-TEST CIRCUIT DIAGRAM AND REVERSE RECOVERY TIME CHARACTERISTIC

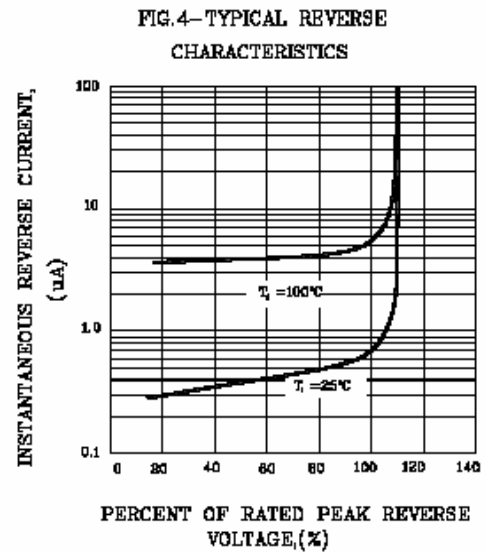
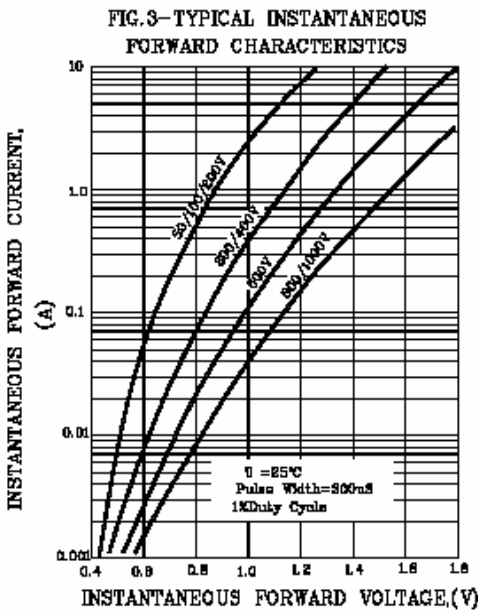
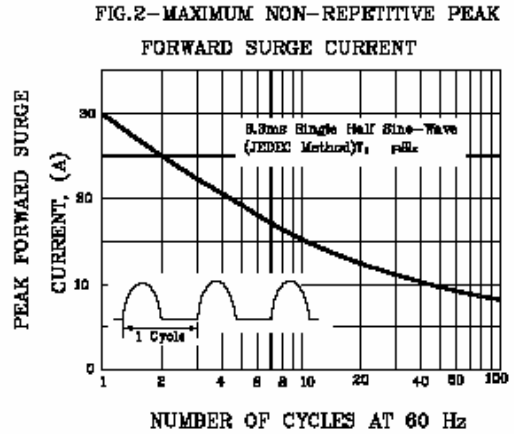
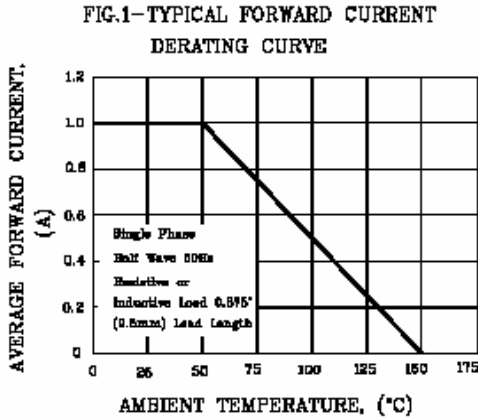
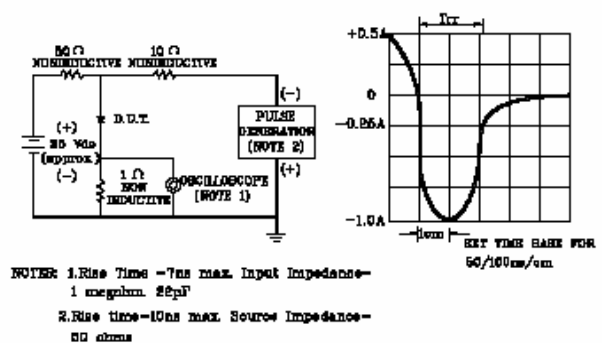
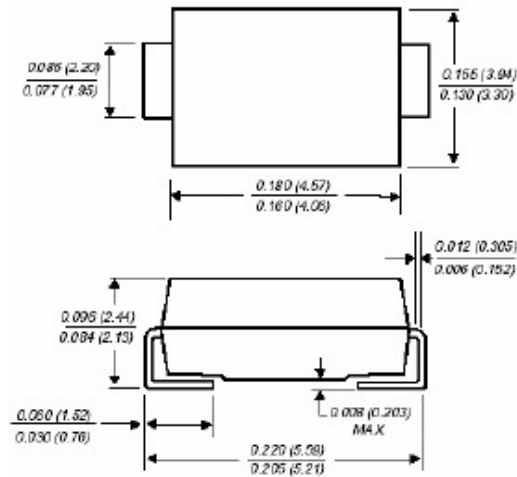

Dimensions in inches (mm)*Dimensions in inches and (millimeters)***DO-214AA (SMB)****Contact us:****US HEADQUARTERS****MEI SEMI INC.****2902** Corvin Drive, Santa Clara, CA95051, USA

Tel: 1-408-733-0808 Fax: 1-408-733-2828