



AUTOMOTIVE RECTIFIER

DR351 THRU DR356

FEATURES

- Low leakage
- Low forward voltage drop
- High current capability
- High forward surge current capability

MECHANICAL DATA

- Technology: vacuum soldered
- Case: Copper Case
- Silastic: UL94V - 0rate flame retardant
- Polarity: As marked of case bottom.
- Lead: Plated slug, solderable per MIL - STD 202 E method 208C
- Mounting position: Any
- Weight: 0.034 ounce, 0.96grams

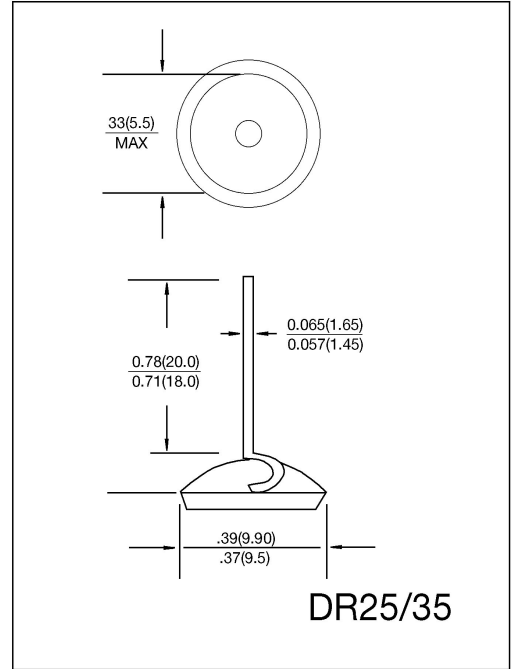

MAXIMUM RATINGS AND ELECTRICAL CHARACTERISTICS

- Ratings at 25°C ambient temperature unless otherwise specified
- Single phase, half wave, 60Hz, resistive or inductive load.
- For capacitive load derate current by 20%

	SYMBOLS	DR351	DR352	DR353	DR354	DR356	UNIT	
Maximum Repetitive Peak Reverse Voltage	V_{RRM}	100	200	300	400	600	Volts	
Maximum RMS Voltage	V_{RMS}	70	140	210	200	420	Volts	
Maximum DC Blocking Voltage	V_{DC}	100	200	300	400	600	Volts	
Maximum Average Forward Rectified Current, at $T_C = 105^\circ C$	$I_{(AV)}$	35					Amps	
Peak Forward Surge Current 8.3ms single half sine - wave superimposed on rated load (JEDEC method)	I_{FSM}	400					Amps	
Rating for Fusing ($t < 8.3ms$)	I^2t	664					A^2S	
Maximum Instantaneous Forward Voltage Drop at 80 A	V_F	1.15					Volts	
Maximum DC Reverse Current at rated DC blocking voltage	I_R	$T_A = 25^\circ C$					5.0	μA
		$T_C = 100^\circ C$					350	
Typical Thermal Resistance at 0.5" (12.7) lead length (Note 1)	$R_{\theta JC}$	0.8					$^\circ C/W$	
Operating and Storage Temperature Range	T_J, T_{STG}	(-65 to +175)					$^\circ C$	

NOTES:

1. P.C.B. mounted