

Surface mount low leakage diode

BAV3004W

FEATURES

- Low Leakage Current.
- High Reverse Breakdown Voltage.
- Fast Switching Speed.
- Surface Mount Package Ideally Suited for Automatic Insertion.

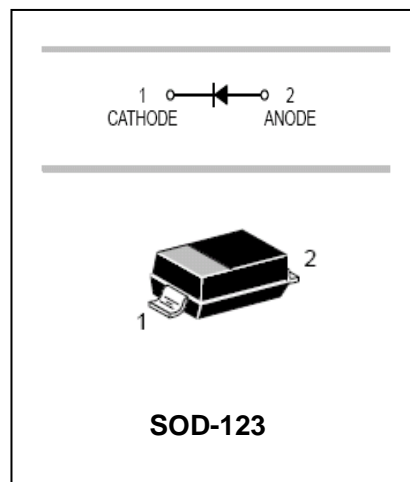

APPLICATIONS

- Surface mount fast switching diode.

ORDERING INFORMATION

Type No.	Marking	Package Code
BAV3004W	4P	SOD-123

MAXIMUM RATING @ Ta=25°C unless otherwise specified

Characteristic	Symbol	Value	Unit
Peak Repetitive Reverse Voltage	V_{RRM}	350	V
Working Peak Reverse Voltage	V_{RWM}	300	V
DC Reverse Voltage	V_R		V
RMS Reverse Voltage	$V_{R(RMS)}$	212	V
Forward Continuous Current	I_{FM}	225	mA
Repetitive Peak Forward Current	I_{FRM}	625	mA
Non-Repetitive Peak Forward Surge Current	I_{FSM}	4.0	A
@t=1.0us		1.0	
@t=1.0s			
Power Dissipation	P_d	400	mW
Thermal Resistance Junction to Ambient Air	$R_{\theta JA}$	312	°C/W
Operating and Storage Temperature Range	T_j, T_{STG}	-65 to +150	°C

Surface mount low leakage diode

BAV3004W

ELECTRICAL CHARACTERISTICS @ Ta=25°C unless otherwise specified

Characteristic	Symbol	Min	Typ	Max	Unit	Test Condition
Reverse Breakdown Voltage	$V_{(BR)R}$	350		-	V	$I_R=150\mu A$
Forward Voltage	V_F	-	0.78 0.93 1.03	0.87 1.0 1.25	V	$I_F=20mA$ $I_F=100mA$ $I_F=200mA$
Reverse Current	I_R	-	30 35	100 100	nA uA	$V_R=240V, T_j=25^\circ C$ $V_R=240V, T_j=150^\circ C$
Total Capacitance	C_T	-	1.0	5.0	pF	$V_R=0V, f=1.0MHz$
Reverse Recovery Time	t_{rr}	-	-	50	ns	$I_F=I_R=30mA,$ $I_{rr}=0.1 \times I_R, R_L=100\Omega$

TYPICAL CHARACTERISTICS @ Ta=25°C unless otherwise specified

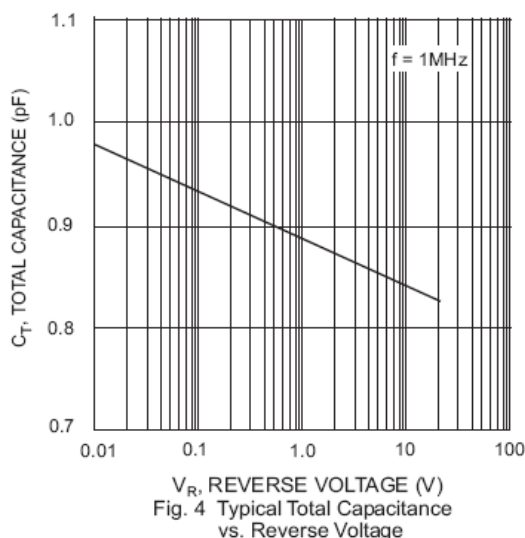
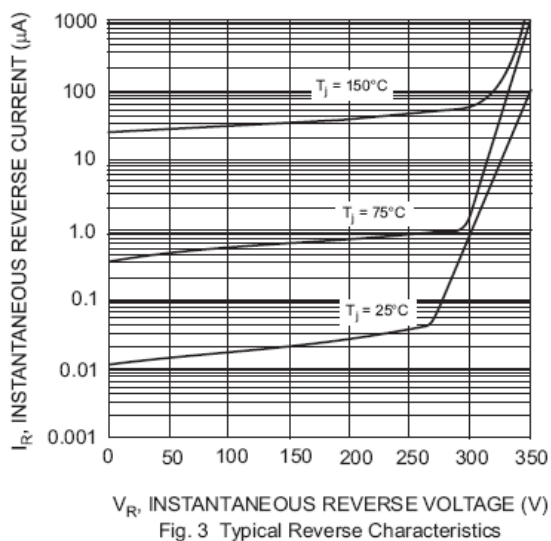
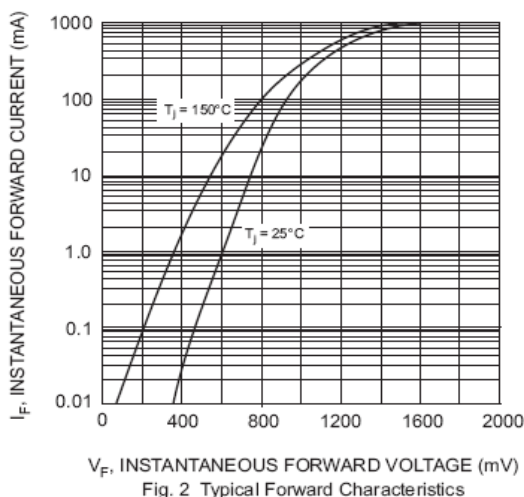
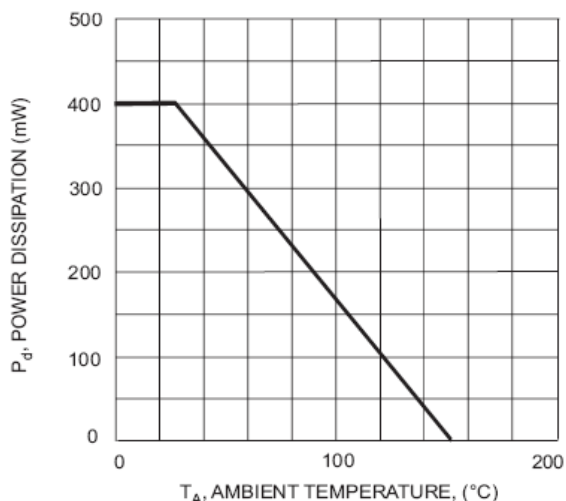

Surface mount low leakage diode

BAV3004W

PACKAGE OUTLINE

Plastic surface mounted package

SOD-123

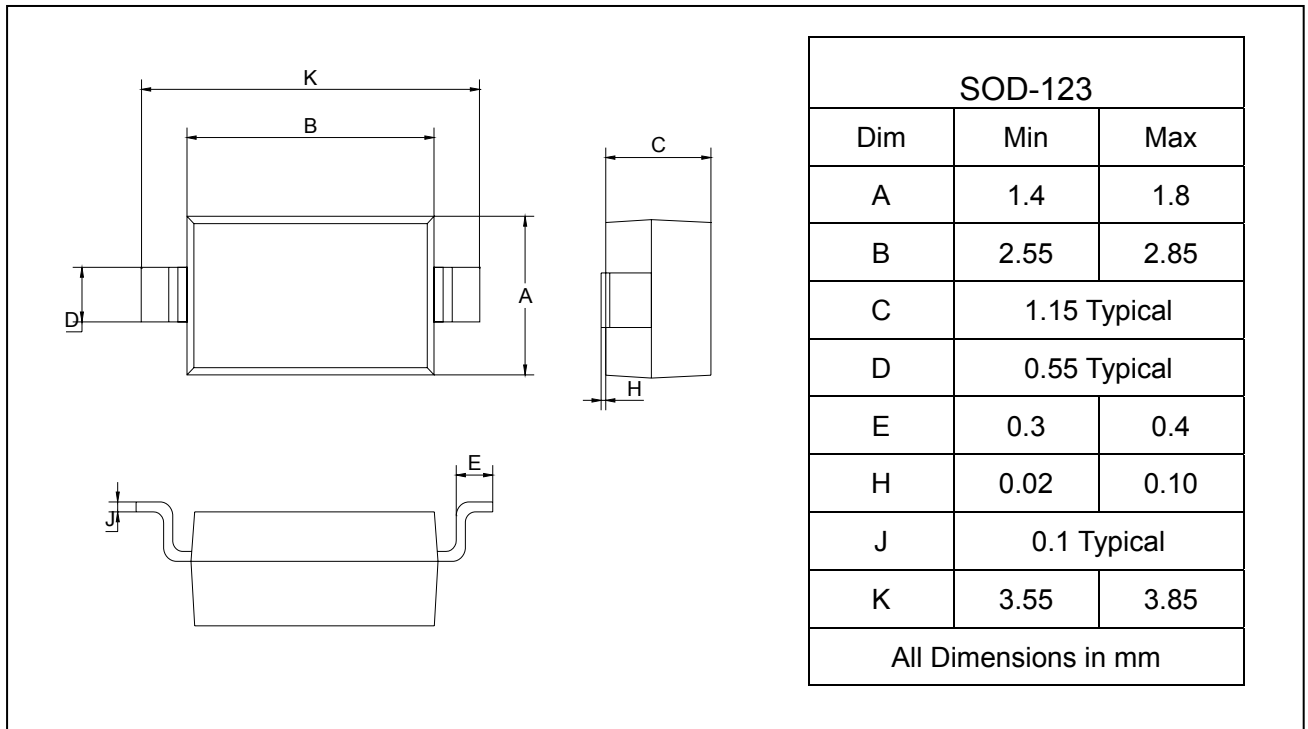

SOLDERING FOOTPRINT

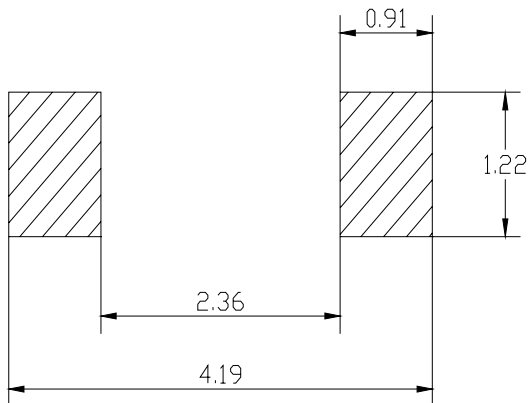

Unit: mm

PACKAGE INFORMATION

Device	Package	Shipping
BAV3004W	SOD-123	3000/Tape&Reel