

# JCS12N65T

## 主要参数 MAIN CHARACTERISTICS

$I_D$	12.0A
$V_{DSS}$	650 V
$R_{Dson-max}$ (@ $V_{gs}=10V$ )	0.78 $\Omega$
$Q_g-typ$	39 nC

### 用途

- 高频开关电源
- 电子镇流器
- LED 电源

### 产品特性

- 低栅极电荷
- 低  $C_{rss}$  (典型值 23pF)
- 开关速度快
- 产品全部经过雪崩测试
- 高抗  $dv/dt$  能力
- RoHS 产品

### APPLICATIONS

- High efficiency switch mode power supplies
- Electronic lamp ballasts based on half bridge
- LED power supplies

### FEATURES

- Low gate charge
- Low  $C_{rss}$  (typical 23pF)
- Fast switching
- 100% avalanche tested
- Improved  $dv/dt$  capability
- RoHS product

## 封装 Package

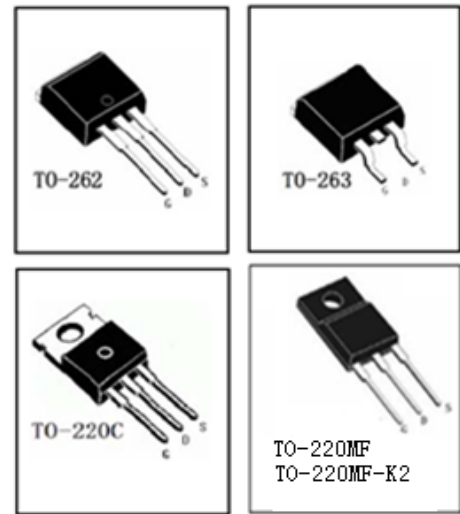
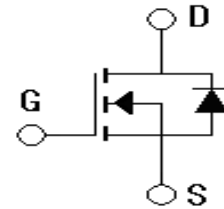

## 订货信息 ORDER MESSAGE

订货型号 Order codes				印记 Marking	封装 Package
有卤-条管 Halogen-Tube	无卤-条管 Halogen-Free-Tube	有卤-编带 Halogen-Reel	无卤-编带 Halogen-Free-Reel		
JCS12N65BT-B-B	JCS12N65BT-B-BR	N/A	N/A	JCS12N65BT	TO-262
JCS12N65ST-S-B	JCS12N65ST-S-BR	JCS12N65ST-S-A	JCS12N65ST-S-AR	JCS12N65ST	TO-263
JCS12N65CT-C-B	JCS12N65CT-C-BR	N/A	N/A	JCS12N65CT	TO-220C
JCS12N65FT-F-B	JCS12N65FT-F-BR	N/A	N/A	JCS12N65FT	TO-220MF
JCS12N65FT-F2-B	JCS12N65FT-F2-BR	N/A	N/A	JCS12N65FT	TO-220MF-K2

绝对最大额定值 ABSOLUTE RATINGS ( $T_c=25^\circ\text{C}$ )

项 目 Parameter	符 号 Symbol	数 值 Value		单 位 Unit
		JCS12N65ST/BT/CT	JCS12N65FT	
最高漏极—源极直流电压 Drain-Source Voltage	$V_{DSS}$	650	650	V
连续漏极电流 Drain Current -continuous	$I_D$ $T=25^\circ\text{C}$ $T=100^\circ\text{C}$	12	12*	A
		7.6	7.6*	A
最大脉冲漏极电流 (注 1) Drain Current – pulse (note 1)	$I_{DM}$	48	48*	A
最高栅源电压 Gate-Source Voltage	$V_{GSS}$	$\pm 30$		V
单脉冲雪崩能量 (注 2) Single Pulsed Avalanche Energy (note 2)	$E_{AS}$	880		mJ
雪崩电流 (注 1) Avalanche Current (note 1)	$I_{AR}$	12		A
重复雪崩能量 (注 1) Repetitive Avalanche Current (note 1)	$E_{AR}$	25		mJ
二极管反向恢复最大电压变化速率 (注 3) Peak Diode Recovery dv/dt (note 3)	dv/dt	4.5		V/ns
耗散功率 Power Dissipation	$P_D$ $T_C=25^\circ\text{C}$ -Derate above $25^\circ\text{C}$	192.3	42.5	W
		1.53	0.34	W/ $^\circ\text{C}$
最高结温及存储温度 Operating and Storage Temperature Range	$T_J, T_{STG}$	$-55 \sim +150$		$^\circ\text{C}$
引线最高焊接温度 Maximum Lead Temperature for Soldering Purposes	$T_L$	300		$^\circ\text{C}$

\*漏极电流由最高结温限制

\*Drain current limited by maximum junction temperature

项 目 Parameter	符 号 Symbol	测试条件 Tests conditions	最小 Min	典型 Typ	最大 Max	单位 Units
<b>关态特性 Off –Characteristics</b>						
漏—源击穿电压 Drain-Source Voltage	$BV_{DSS}$	$I_D=250\mu A, V_{GS}=0V$	650	-	-	V
击穿电压温度特性 Breakdown Voltage Temperature Coefficient	$\Delta BV_{DSS}/\Delta T_J$	$I_D=250\mu A$ , referenced to $25^\circ C$	-	0.5	-	$V/^\circ C$
零栅压下漏极漏电流 Zero Gate Voltage Drain Current	$I_{DSS}$	$V_{DS}=650V, V_{GS}=0V,$ $T_C=25^\circ C$	-	-	1	$\mu A$
		$V_{DS}=480V, T_C=125^\circ C$	-	-	10	$\mu A$
正向栅极体漏电流 Gate-body leakage current, forward	$I_{GSSF}$	$V_{DS}=0V, V_{GS}=30V$	-	-	100	nA
反向栅极体漏电流 Gate-body leakage current, reverse	$I_{GSSR}$	$V_{DS}=0V, V_{GS}=-30V$	-	-	-100	nA
<b>通态特性 On-Characteristics</b>						
阈值电压 Gate Threshold Voltage	$V_{GS(th)}$	$V_{DS} = V_{GS}, I_D=250\mu A$	3.0	-	5.0	V
静态导通电阻 Static Drain-Source On-Resistance	$R_{DS(ON)}$	$V_{GS} = 10V, I_D=6A$ $25^\circ C$	-	0.71	0.78	$\Omega$
		$V_{GS} = 10V, I_D=6A$ $100^\circ C$	-	1.24	1.8	$\Omega$
		$V_{GS} = 10V, I_D=6A$ $150^\circ C$	-	1.85	2.5	$\Omega$
正向跨导 Forward Transconductance	$g_{fs}$	$V_{DS} = 40V, I_D=6A$ (note 4)	-	13	-	S
<b>动态特性 Dynamic Characteristics</b>						
栅极电阻 Gate resistance	$R_g$	$F=1.0MHz$ open drain	0.3	-	4.0	$\Omega$
输入电容 Input capacitance	$C_{iss}$	$V_{DS}=25V,$ $V_{GS}=0V,$ $f=1.0MHz$	800	1790	2410	pF
输出电容 Output capacitance	$C_{oss}$		80	175	229	pF
反向传输电容 Reverse transfer capacitance	$C_{riss}$		10	23	31	pF

**电特性 ELECTRICAL CHARACTERISTICS**

开关特性 Switching Characteristics						
延迟时间 Turn-On delay time	$t_d(\text{on})$	$V_{DD}=325V, I_D=12A, R_G=25\Omega$ (note 4, 5)	-	78	102	ns
上升时间 Turn-On rise time	$t_r$		-	133	175	ns
延迟时间 Turn-Off delay time	$t_d(\text{off})$		-	233	305	ns
下降时间 Turn-Off Fall time	$t_f$		-	104	160	ns
栅极电荷总量 Total Gate Charge	$Q_g$	$V_{DS}=520V,$ $I_D=12A$ $V_{GS}=10V$ (note 4, 5)	-	39	52	nC
栅-源电荷 Gate-Source charge	$Q_{gs}$		-	8.5	20	nC
栅-漏电荷 Gate-Drain charge	$Q_{gd}$		-	20	50	nC
漏-源二极管特性及最大额定值 Drain-Source Diode Characteristics and Maximum Ratings						
正向最大连续电流 Maximum Continuous Drain-Source Diode Forward Current		$I_S$	-	-	12	A
正向最大脉冲电流 Maximum Pulsed Drain-Source Diode Forward Current		$I_{SM}$	-	-	48	A
正向压降 Drain-Source Diode Forward Voltage	$V_{SD}$	$V_{GS}=0V,$ $I_S=12A$	-	-	1.39	V
反向恢复时间 Reverse recovery time	$t_{rr}$	$V_{GS}=0V, I_S=12A$ $di_f/dt=100A/\mu s$ (note 4)	-	418	900	ns
反向恢复电荷 Reverse recovery charge	$Q_{rr}$		-	4.85	10.0	$\mu C$

**热特性 THERMAL CHARACTERISTIC**

项 目 Parameter	符 号 Symbol	最大 Max		单 位 Unit
		JCS12N65BT/CT	JCS12N65FT	
结到管壳的热阻 Thermal Resistance, Junction to Case	$R_{th(j-c)}$	0.65	2.94	$^{\circ}C/W$
结到环境的热阻 Thermal Resistance, Junction to Ambient	$R_{th(j-A)}$	62.5	62.5	$^{\circ}C/W$

注释:

- 1: 脉冲宽度由最高结温限制
- 2:  $L=11.2mH, I_{AS}=12A, V_{DD}=50V, R_G=25\Omega$ , 起始结温  $T_J=25^{\circ}C$
- 3:  $I_{SD} \leq 12A, di/dt \leq 300A/\mu s, V_{DD} \leq BV_{DSS}$ , 起始结温  $T_J=25^{\circ}C$
- 4: 脉冲测试: 脉冲宽度  $\leq 300\mu s$ , 占空比  $\leq 2\%$
- 5: 基本与工作温度无关

Notes:

- 1: Pulse width limited by maximum junction temperature
- 2:  $L=11.2mH, I_{AS}=12A, V_{DD}=50V, R_G=25\Omega$ , Starting  $T_J=25^{\circ}C$
- 3:  $I_{SD} \leq 12A, di/dt \leq 300A/\mu s, V_{DD} \leq BV_{DSS}$ , Starting  $T_J=25^{\circ}C$
- 4: Pulse Test: Pulse Width  $\leq 300\mu s$ , Duty Cycle  $\leq 2\%$
- 5: Essentially independent of operating temperature

特征曲线 ELECTRICAL CHARACTERISTICS (curves)

**On-Region Characteristics**

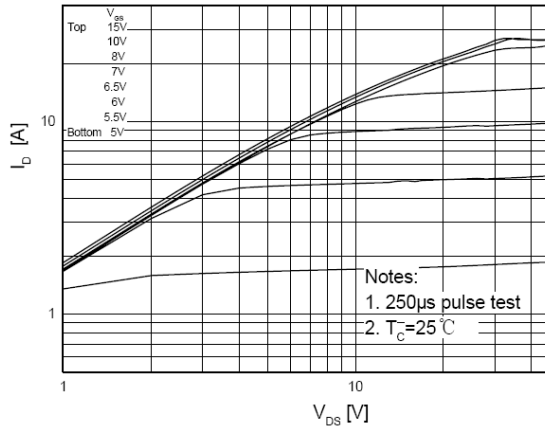

**Transfer Characteristics**

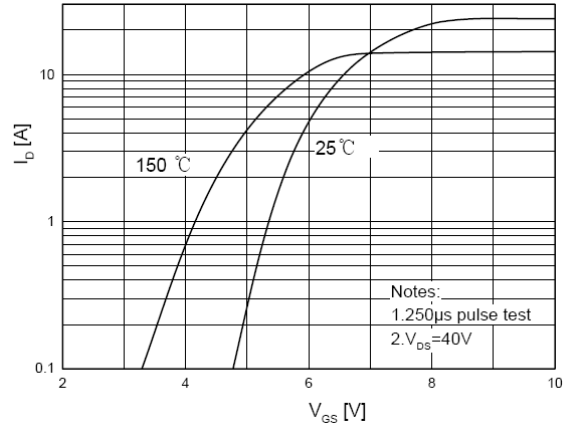

**On-Resistance Variation vs. Drain Current and Gate Voltage**

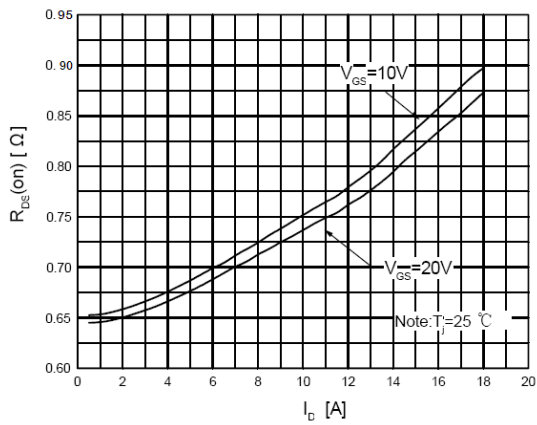

**Body Diode Forward Voltage Variation vs. Source Current and Temperature**

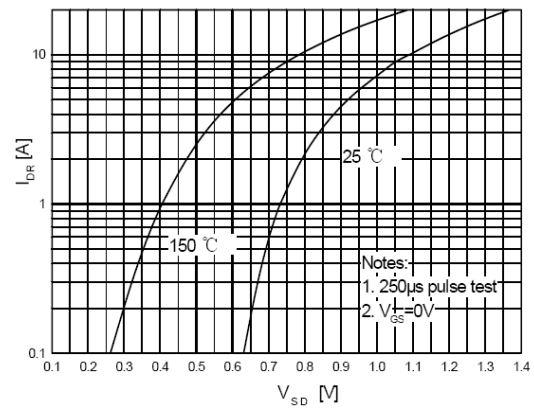

**Capacitance Characteristics**

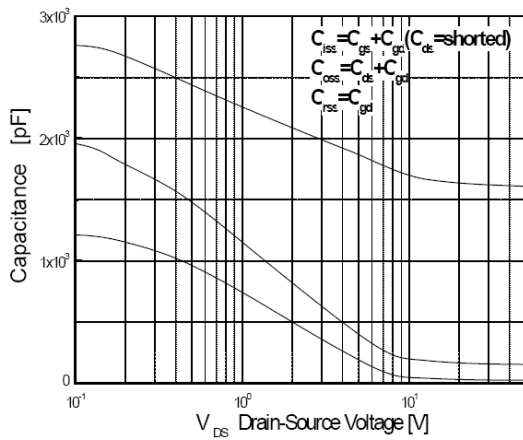

**Gate Charge Characteristics**

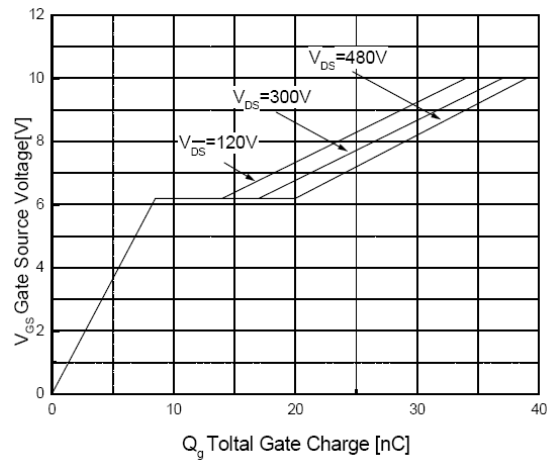

特征曲线 ELECTRICAL CHARACTERISTICS (curves)

**Breakdown Voltage Variation vs. Temperature**

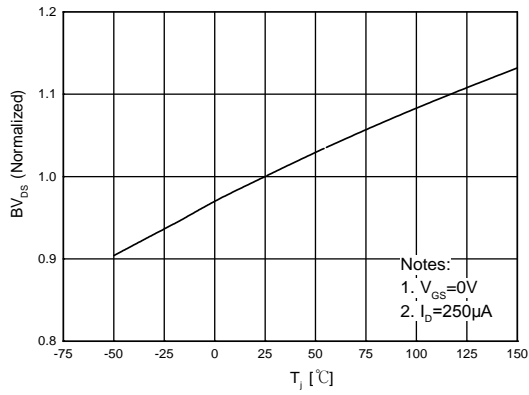

**On-Resistance Variation vs. Temperature**

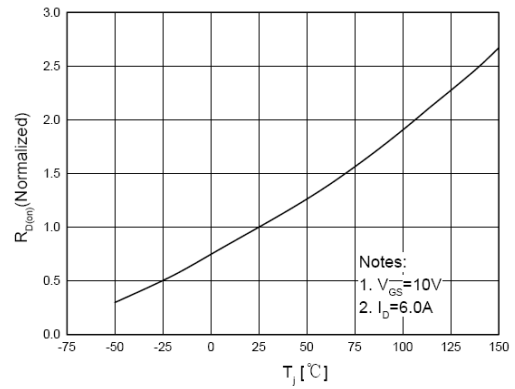

**Gate Threshold Voltage Variation vs. Temperature**

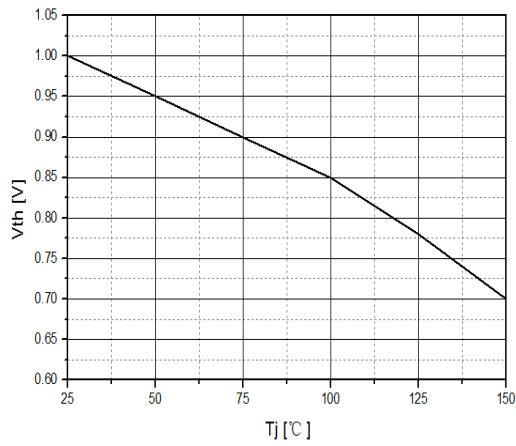

**Single Pulsed Avalanche Energy Variation vs. Temperature**

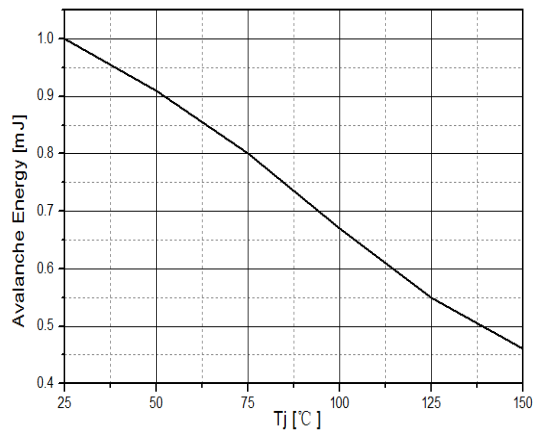

特征曲线 ELECTRICAL CHARACTERISTICS (curves)

**Maximum Safe Operating Area  
For JCS12N65BT/ST/CT**

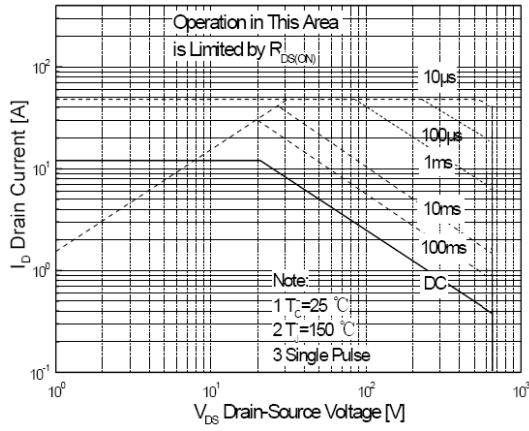

**Maximum Safe Operating Area  
For JCS12N65FT**

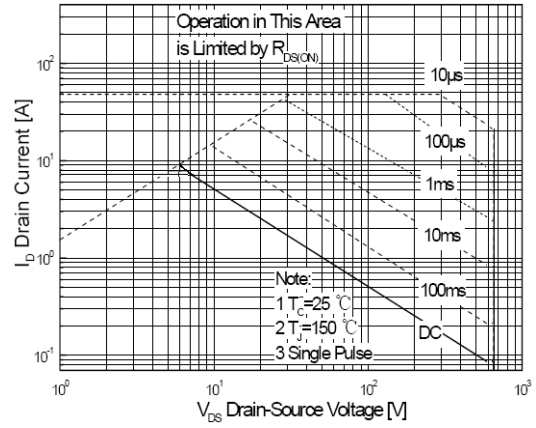

**Maximum Drain Current  
vs. Case Temperature**

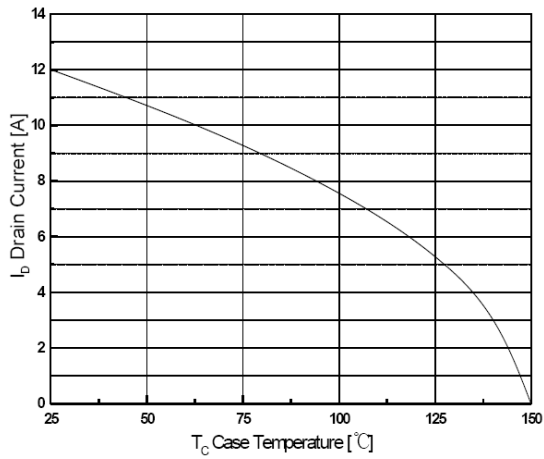

特征曲线 ELECTRICAL CHARACTERISTICS (curves)

Transient Thermal Response Curve For JCS12N65ST/BT/CT

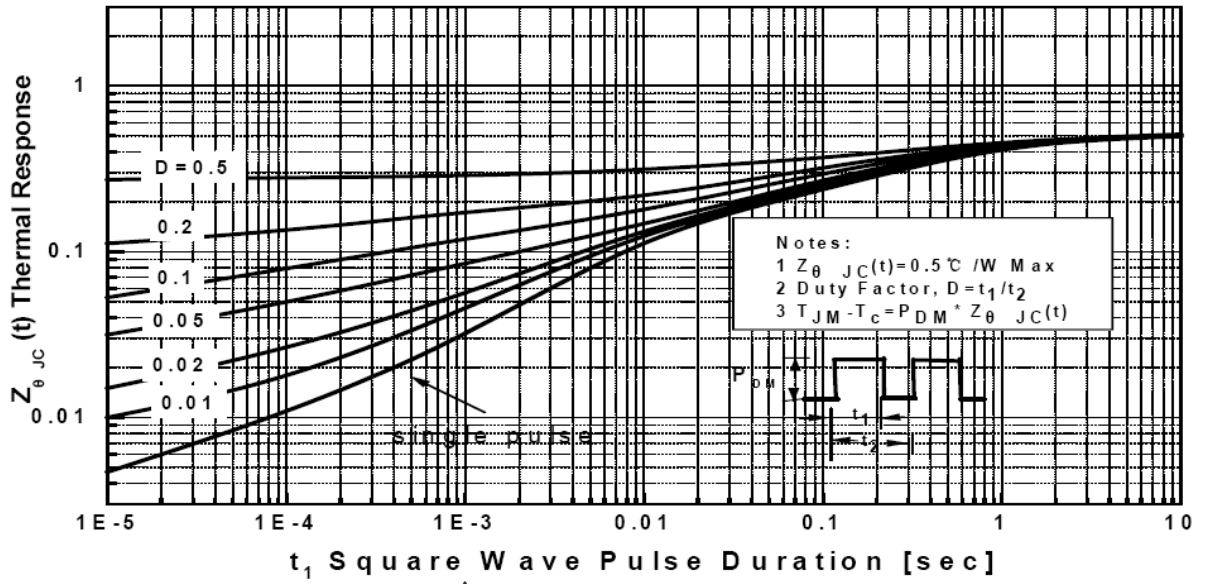

Transient Thermal Response Curve For JCS12N65FT

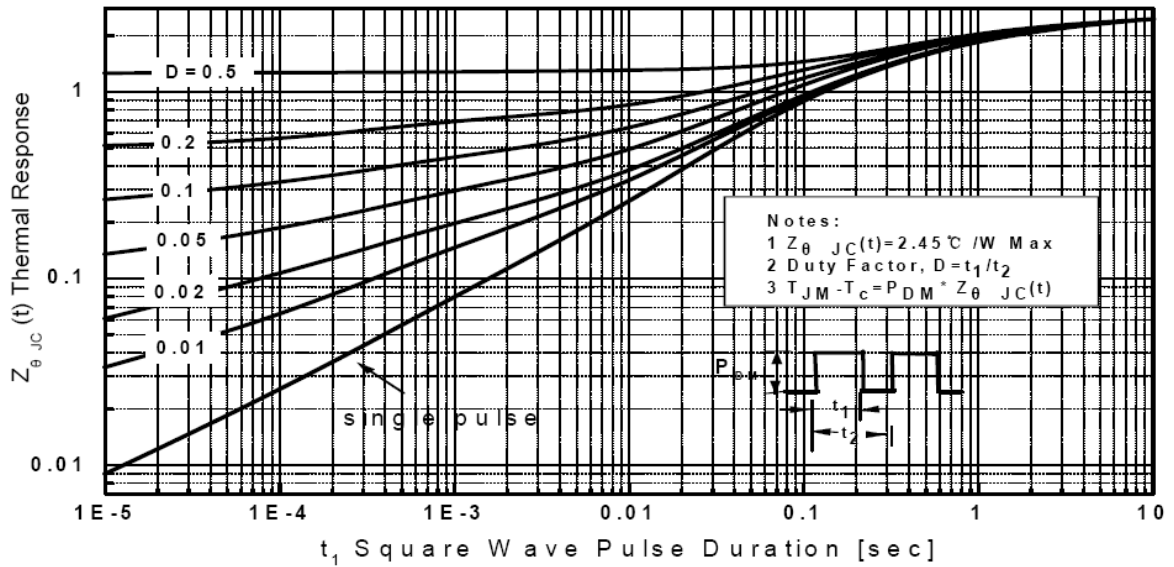



外形尺寸 PACKAGE MECHANICAL DATA

**TO-220C**

**单位 Unit: mm**

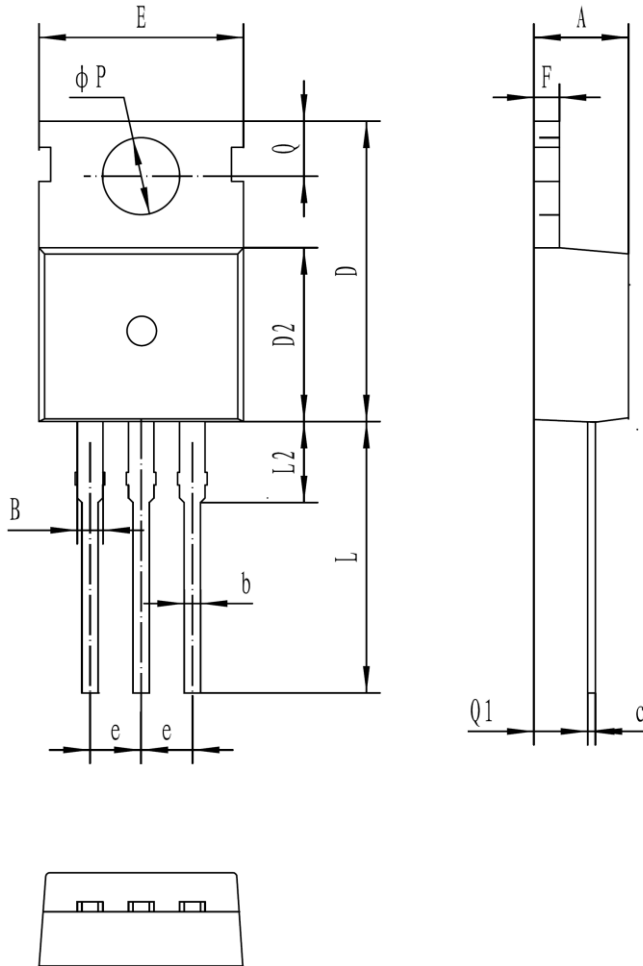

符号 symbol	MIN	MAX
A	4.30	4.70
B	1.22	1.47
b	0.70	0.95
c	0.40	0.65
D	15.20	16.20
D2	9.00	9.40
E	9.70	10.10
e	2.39	2.69
F	1.25	1.40
L	12.60	13.60
L2	2.80	3.20
Q	2.60	3.00
Q1	2.20	2.60
P	3.50	3.80

外形尺寸 PACKAGE MECHANICAL DATA

TO-262

单位 Unit: mm

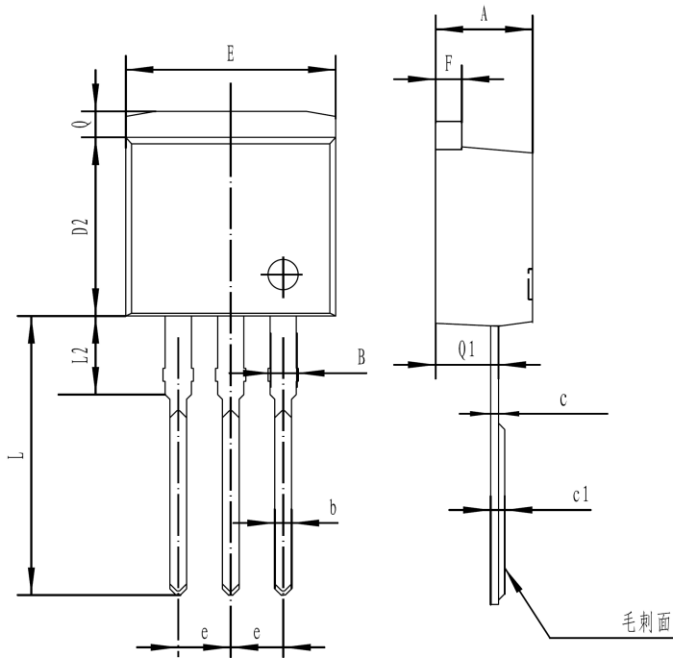

符号 symbol	MIN	MAX
A	4.40	4.90
B	1.10	1.40
b	0.70	0.95
c	0.30	0.60
c1	0.33	0.63
D2	8.20	9.20
E	9.60	10.50
e	2.39	2.69
F	1.20	1.35
L	13.11	14.61
L2	3.55	4.05
Q	1.10	1.40
Q1	2.65	2.85

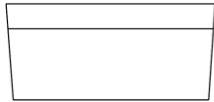

外形尺寸 PACKAGE MECHANICAL DATA

TO-263

单位 Unit: mm

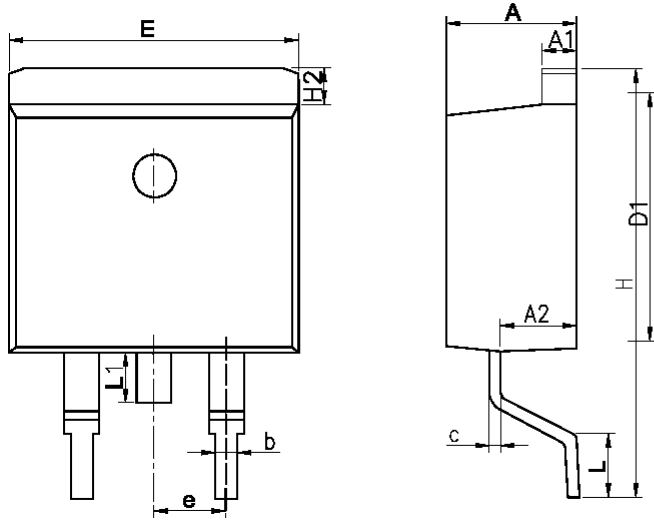

SYMBOL	MM	
	MIN	MAX
A	4.30	4.80
A1	1.12	1.42
A2	2.54	2.84
b	0.67	1.00
c	0.28	0.52
D1	8.40	9.00
E	9.80	10.46
e	2.54BSC	
H	14.00	16.00
H2	1.12	1.45
L	1.50	3.10
L1	1.45	1.70

编带 REEL

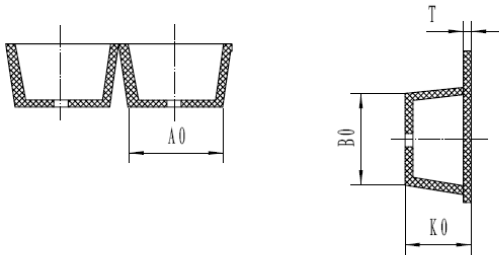
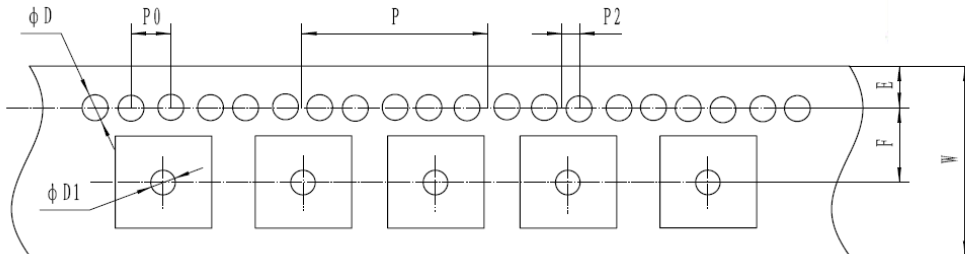

产品尺寸规格 (UNIT: mm)					
规格	W	A0	E	F	D
尺寸	24 ± 0.3	10.9 ± 0.1	1.75 ± 0.1	11.5 ± 0.1	1.5 +0.1/-0
规格	D1	P0	P2	P	T
尺寸	1.5 +0.1/-0	4 ± 0.1	2 ± 0.1	16 ± 0.1	0.35 ± 0.05
规格	K0	B0			
尺寸	4.9 ± 0.1	16.0 ± 0.1			

外形尺寸 PACKAGE MECHANICAL DATA

TO-220MF

单位 Unit: mm

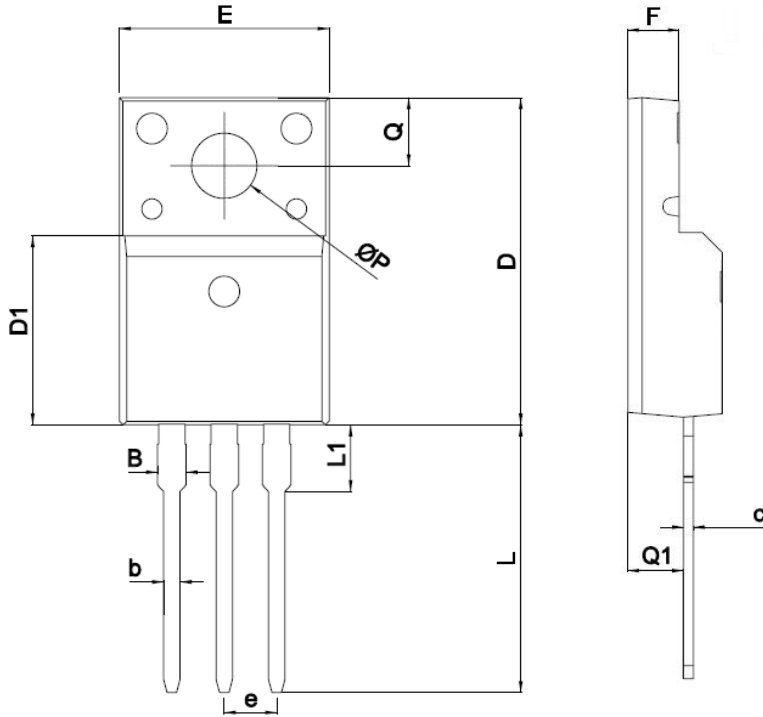

SYMBOL	mm	
	MIN	MAX
A	4.5	4.9
B		1.47
b	0.7	0.9
c	0.45	0.60
D	15.67	16.07
D1	9.04	9.20
e	2.54TYPE	
E	9.96	10.36
F	2.34	2.74
L	12.58	13.38
L1	3.13	3.33
Q	3.2	3.4
Q1	2.56	2.96
$\Phi P$	3.08	3.28

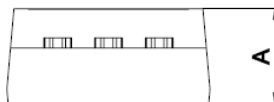

外形尺寸 PACKAGE MECHANICAL DATA

**TO-220MF-K2**

单位 Unit: mm

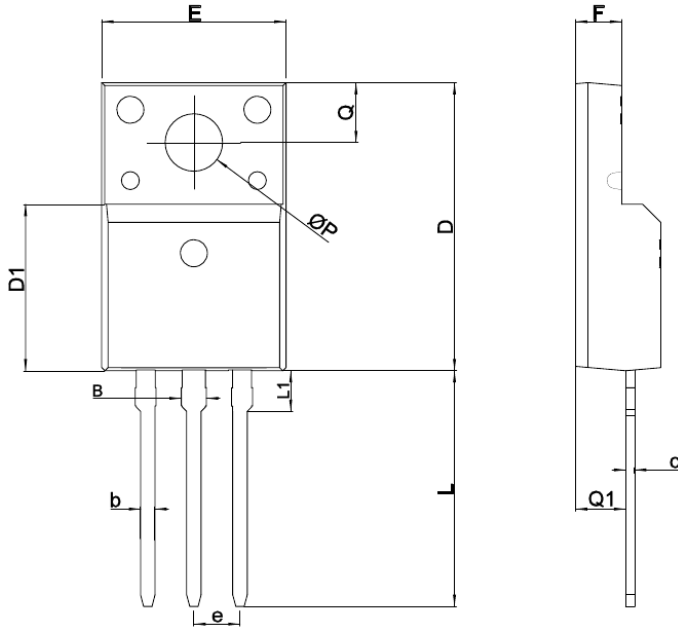

SYMBOL	mm	
	MIN	MAX
A	4.5	4.9
B		1.27
b	0.59	0.79
c	0.45	0.60
D	15.67	16.07
D1	8.97	9.37
e	2.54TYPE	
E	9.96	10.36
F	2.34	2.74
L	12.65	13.35
L1	1.80	2.20
Q	3.2	3.4
Q1	2.56	2.96
ΦP	3.08	3.28