

JCS7N65B

主要参数 MAIN CHARACTERISTICS

I_D	7.0 A
V_{DSS}	650 V
$R_{dson-max}$ (@ $V_{GS}=10V$)	1.3 Ω
Q_g-typ	25 nC

用途

- 高频开关电源
- 电子镇流器
- LED 电源

产品特性

- 低栅极电荷
- 低 C_{RSS} (典型值 16pF)
- 开关速度快
- 产品全部经过雪崩测试
- 高抗 dv/dt 能力
- RoHS 产品

APPLICATIONS

- High frequency switching mode power supply
- Electronic ballast
- LED power supply

FEATURES

- Low gate charge
- Low C_{RSS} (typical 16pF)
- Fast switching
- 100% avalanche tested
- Improved dv/dt capability
- RoHS product

封装 Package

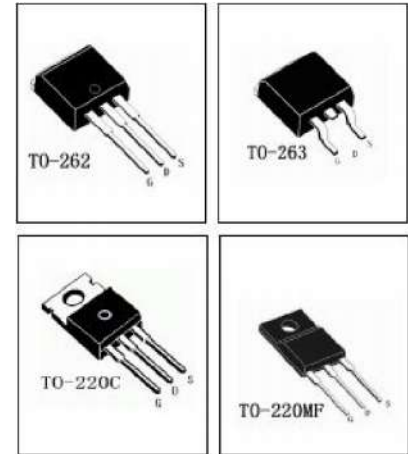
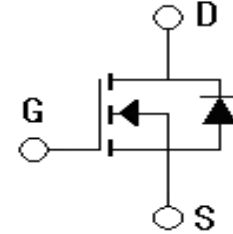

订货信息 ORDER MESSAGE

订货型号 Order codes				印 记 Marking	封 装 Package
有卤-条管 Halogen-Tube	无卤-条管 Halogen-Free-Tube	有卤-编带 Halogen-Reel	无卤-编带 Halogen-Free-Reel		
JCS7N65BB-B-B	JCS7N65BB-B-BR	N/A	N/A	JCS7N65BB	TO-262
JCS7N65SB-S-B	JCS7N65SB-S-BR	JCS7N65SB-S-A	JCS7N65SB-S-AR	JCS7N65SB	TO-263
JCS7N65CB-C-B	JCS7N65CB-C-BR	N/A	N/A	JCS7N65CB	TO-220C
JCS7N65FB-F-B	JCS7N65FB-F-BR	N/A	N/A	JCS7N65FB	TO-220MF



绝对最大额定值 ABSOLUTE RATINGS (Tc=25°C)

项 目 Parameter	符 号 Symbol	数 值 Value		数 值 Value
		JCS7N65 CB/SB/BB	JCS7N65FB (TO-220MF)	
最高漏极-源极直流电压 Drain-Source Voltage	V _{DSS}	650	650	V
连续漏极电流 Drain Current -continuous	I _D T=25°C T=100°C	7.0	7.0*	A
		4.3	4.3*	A
最大脉冲漏极电流 (注 1) Drain Current - pulse (note 1)	I _{DM}	28	28*	A
最高栅源电压 Gate-Source Voltage	V _{GSS}	±30		V
单脉冲雪崩能量 (注 2) Single Pulsed Avalanche Energy (note 2)	E _{AS}	590		mJ
雪崩电流 (注 1) Avalanche Current (note 1)	I _{AR}	7.0		A
重复雪崩能量 (注 1) Repetitive Avalanche Energy (note 1)	E _{AR}	14.0		mJ
二极管反向恢复最大电压 变化速率 (注 3) Peak Diode Recovery dv/dt (note 3)	dv/dt	4.5		V/ns
耗散功率 Power Dissipation	P _D T _C =25°C -Derate above 25°C	142	50	W
		1.14	0.4	W/°C
最高结温及存储温度 Operating and Storage Temperature Range	T _J , T _{STG}	-55~+150		°C
引线最高焊接温度 Maximum Lead Temperature for Soldering Purposes	T _L	300		°C

*漏极电流由最高结温限制



*Drain current limited by maximum junction temperature

电特性 ELECTRICAL CHARACTERISTICS

项 目 Parameter	符 号 Symbol	测试条件 Tests conditions	最小 Min	典型 Typ	最大 Max	单 位 Units
关态特性 Off –Characteristics						
漏—源击穿电压 Drain-Source Voltage	BV_{DSS}	$I_D=250\mu A, V_{GS}=0V$	650	-	-	V
击穿电压温度特性 Breakdown Voltage Temperature Coefficient	$\Delta BV_{DSS}/\Delta T_J$	$I_D=250\mu A$, referenced to $25^\circ C$	-	0.65	-	V/ $^\circ C$
零栅压下漏极漏电流 Zero Gate Voltage Drain Current	I_{DSS}	$V_{DS}=650V, V_{GS}=0V,$ $T_C=25^\circ C$	-	-	10	μA
		$V_{DS}=520V, T_C=125^\circ C$	-	-	100	μA
正向栅极体漏电流 Gate-body leakage current, forward	I_{GSSF}	$V_{DS}=0V, V_{GS}=30V$	-	-	100	nA
反向栅极体漏电流 Gate-body leakage current, reverse	I_{GSSR}	$V_{DS}=0V, V_{GS}=-30V$	-	-	-100	nA
通态特性 On-Characteristics						
阈值电压 Gate Threshold Voltage	$V_{GS(th)}$	$V_{DS} = V_{GS}, I_D=250\mu A$	2.0	-	4.0	V
静态导通电阻 Static Drain-Source On-Resistance	$R_{DS(ON)}$	$V_{GS} = 10V, I_D=3.5A$	-	1.1	1.3	Ω
正向跨导 Forward Transconductance	g_{fs}	$V_{DS} = 40V, I_D=3.5A$ (note 4)	-	6.2	9	S
动态特性 Dynamic Characteristics						
输入电容 Input capacitance	C_{iss}	$V_{DS}=25V,$ $V_{GS}=0V,$ $f=1.0MHz$	-	1120	1350	pF
输出电容 Output capacitance	C_{oss}		-	115	150	pF
反向传输电容 Reverse transfer capacitance	C_{rss}		-	23	30	pF

电特性 ELECTRICAL CHARACTERISTICS

开关特性 Switching Characteristics							
延迟时间 Turn-On delay time	$t_{d(on)}$	$V_{DD}=300V, I_D=7A, R_G=25\Omega$ (note 4, 5)	-	30	70	ns	
上升时间 Turn-On rise time	t_r		-	80	170	ns	
延迟时间 Turn-Off delay time	$t_{d(off)}$		-	125	260	ns	
下降时间 Turn-Off Fall time	t_f		-	60	110	ns	
栅极电荷总量 Total Gate Charge	Q_g	$V_{DS}=520V,$ $I_D=7A$ $V_{GS}=10V$ (note 4, 5)	-	25	35	nC	
栅-源电荷 Gate-Source charge	Q_{gs}		-	6.0	-	nC	
栅-漏电荷 Gate-Drain charge	Q_{gd}		-	10	-	nC	
漏-源二极管特性及最大额定值 Drain-Source Diode Characteristics and Maximum Ratings							
正向最大连续电流 Maximum Continuous Drain-Source Diode Forward Current		I_S	-	-	7.5	A	
正向最大脉冲电流 Maximum Pulsed Drain-Source Diode Forward Current		I_{SM}	-	-	30	A	
正向压降 Drain-Source Diode Forward Voltage	V_{SD}	$V_{GS}=0V,$ $I_S=7.0A$	-	-	1.4	V	
反向恢复时间 Reverse recovery time	t_{rr}	$V_{GS}=0V, I_S=7.0A$ $di_F/dt=100A/\mu s$ (note 4)	-	315	-	ns	
反向恢复电荷 Reverse recovery charge	Q_{rr}		-	2.6	-	μC	

热特性 THERMAL CHARACTERISTIC

项 目 Parameter	符 号 Symbol	最大 Max		单 位 Unit
		JCS7N65 CB/SB/BB	JCS7N65FB (TO-220MF)	
结到管壳的热阻 Thermal Resistance, Junction to Case	$R_{th(j-c)}$	0.85	2.5	$^{\circ}C/W$
结到环境的热阻 Thermal Resistance, Junction to Ambient	$R_{th(j-A)}$	62.5	38.4	$^{\circ}C/W$

注释:

- 1: 脉冲宽度由最高结温限制
- 2: $L=19.5mH, I_{AS}=7.0A, V_{DD}=50V, R_G=25\Omega$, 起始结温 $T_J=25^{\circ}C$
- 3: $I_{SD} \leq 7.0A, di/dt \leq 300A/\mu s, V_{DD} \leq BV_{DSS}$, 起始结温 $T_J=25^{\circ}C$
- 4: 脉冲测试: 脉冲宽度 $\leq 300\mu s$, 占空比 $\leq 2\%$
- 5: 基本与工作温度无关

版本: 201806I

Notes:

- 1: Pulse width limited by maximum junction temperature
- 2: $L=19.5mH, I_{AS}=7.0A, V_{DD}=50V, R_G=25\Omega$, Starting $T_J=25^{\circ}C$
- 3: $I_{SD} \leq 7.0A, di/dt \leq 300A/\mu s, V_{DD} \leq BV_{DSS}$, Starting $T_J=25^{\circ}C$
- 4: Pulse Test: Pulse Width $\leq 300\mu s$, Duty Cycle $\leq 2\%$
- 5: Essentially independent of operating temperature

特征曲线 ELECTRICAL CHARACTERISTICS (curves)

On-Region Characteristics

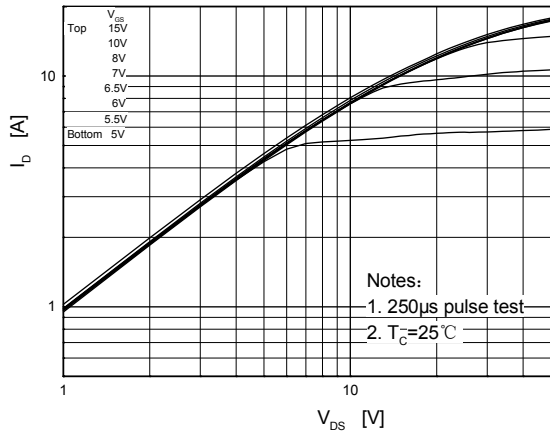

Transfer Characteristics

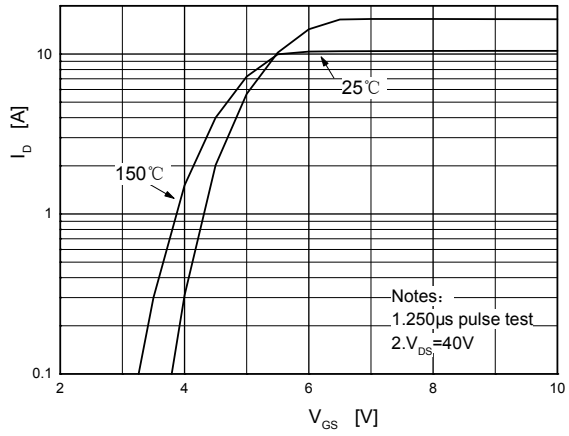

On-Resistance Variation vs. Drain Current and Gate Voltage

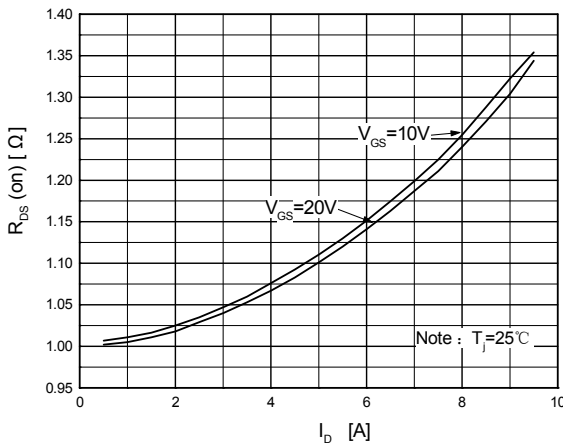

Body Diode Forward Voltage Variation vs. Source Current and Temperature

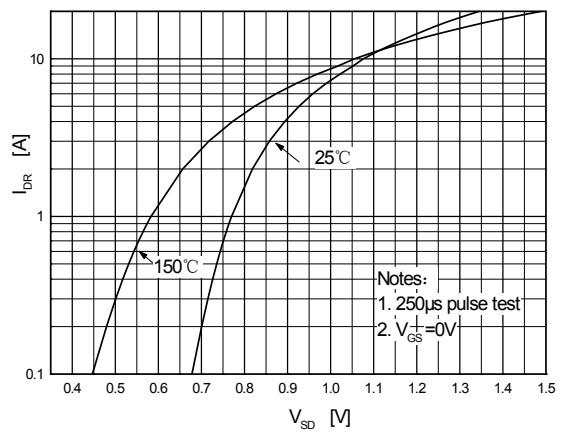

Capacitance Characteristics

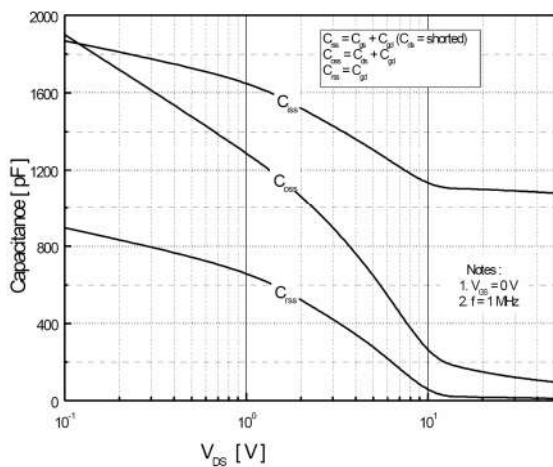

Gate Charge Characteristics

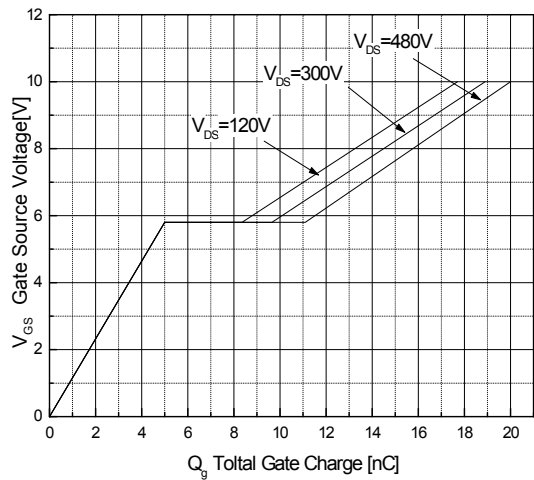

特征曲线 ELECTRICAL CHARACTERISTICS (curves)

Breakdown Voltage Variation vs. Temperature

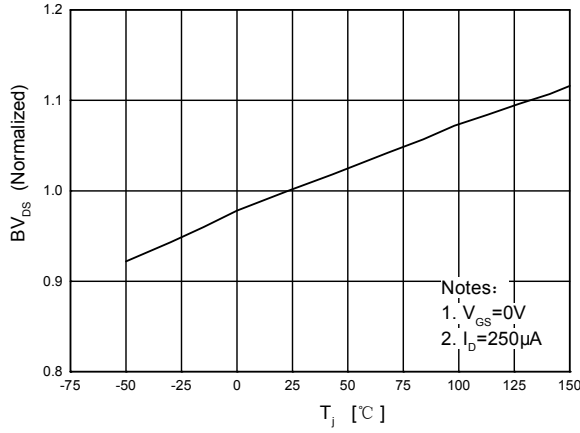

On-Resistance Variation vs. Temperature

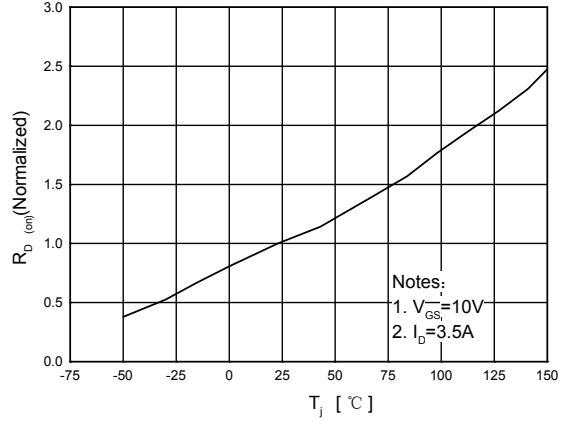

Maximum Safe Operating Area For JCS7N65CB/SB/BB

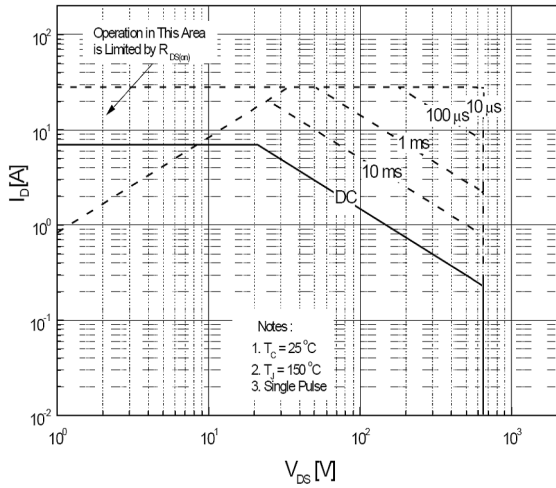

Maximum Safe Operating Area For JCS7N65FB(TO-220MF)

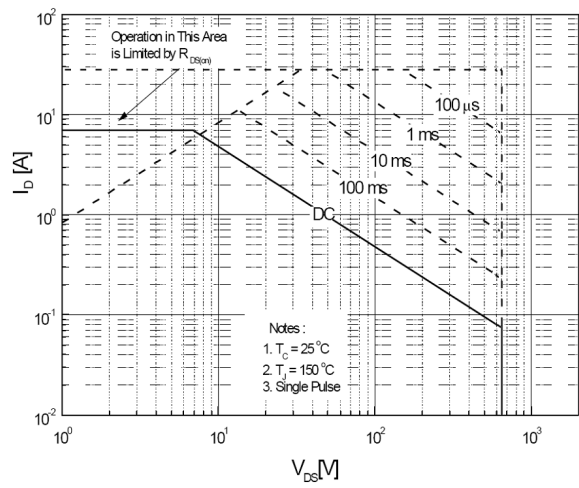

Maximum Drain Current vs. Case Temperature

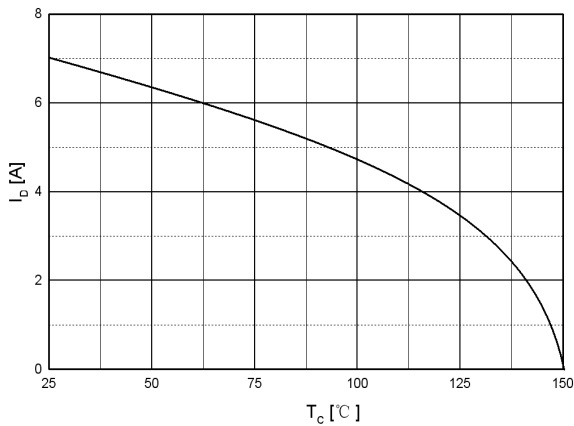

特征曲线 ELECTRICAL CHARACTERISTICS (curves)

**Transient Thermal Response Curve
For JCS7N65CB/SB/BB**

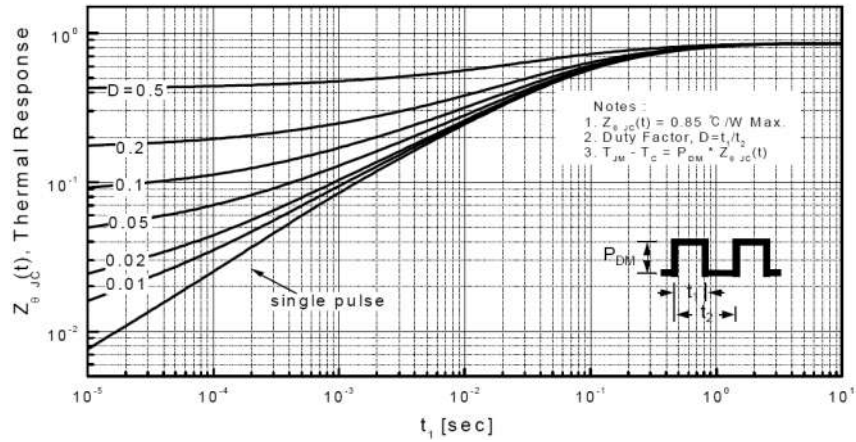

**Transient Thermal Response Curve
For JCS7N65FB(TO-220MF)**

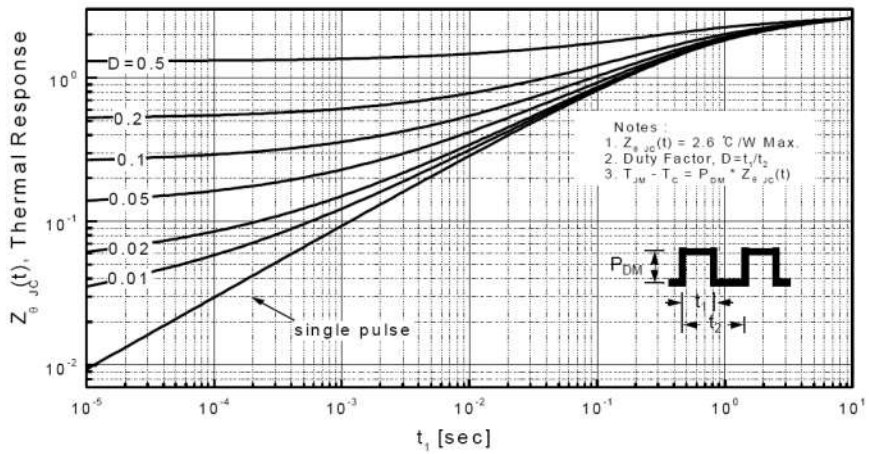

外形尺寸 PACKAGE MECHANICAL DATA

TO-220C

单位 Unit: mm

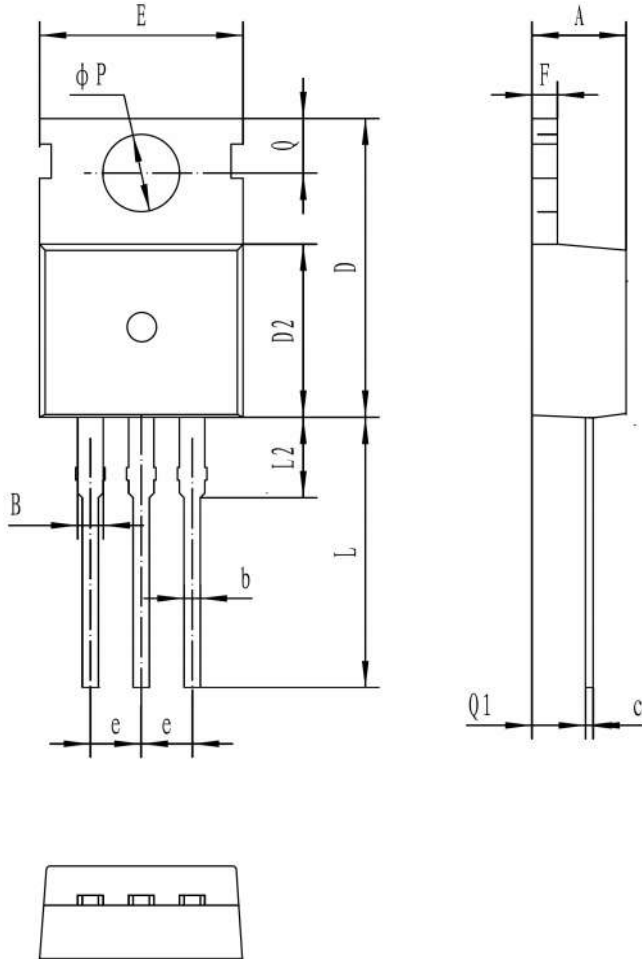

符号 symbol	MIN	MAX
A	4.30	4.70
B	1.10	1.40
b	0.70	0.95
c	0.40	0.65
D	15.20	16.20
D2	9.00	9.40
E	9.70	10.10
e	2.39	2.69
F	1.25	1.40
L	12.60	13.60
L2	2.80	3.20
Q	2.60	3.00
Q1	2.20	2.60
P	3.50	3.80

外形尺寸 PACKAGE MECHANICAL DATA

TO-220MF

单位 Unit: mm

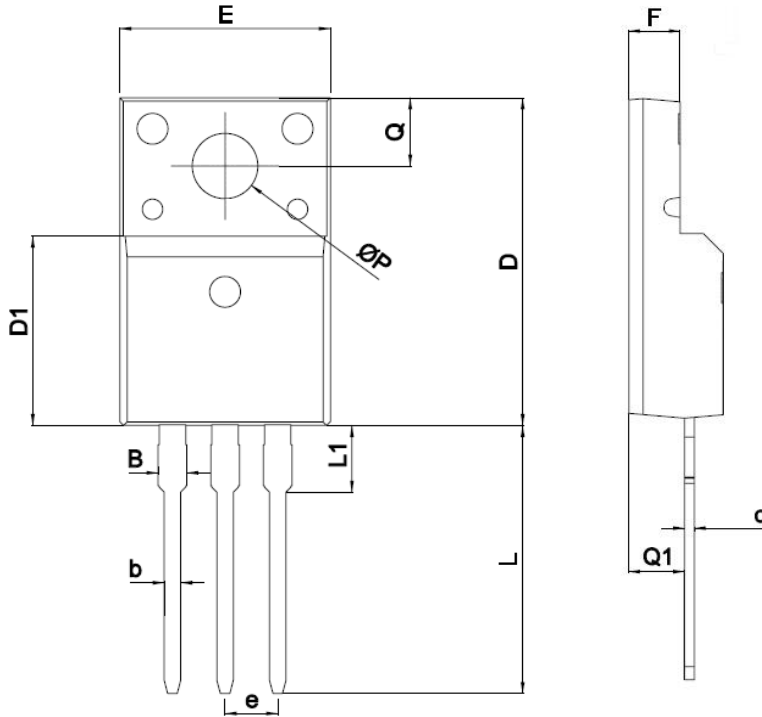

SYMBOL	mm	
	MIN	MAX
A	4.5	4.9
B		1.47
b	0.7	0.9
c	0.45	0.60
D	15.67	16.07
D1	9.04	9.20
e	2.54TYPE	
E	9.96	10.36
F	2.34	2.74
L	12.58	13.38
L1	3.13	3.33
Q	3.2	3.4
Q1	2.56	2.96
ΦP	3.08	3.28



外形尺寸 PACKAGE MECHANICAL DATA

TO-262

单位 Unit: mm

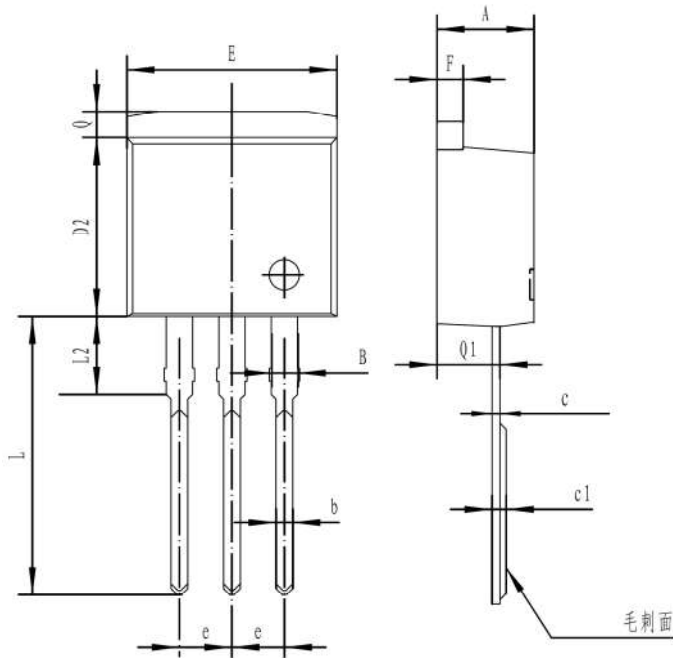

符号 symbol	MIN	MAX
A	4.40	4.90
B	1.10	1.40
b	0.70	0.95
c	0.30	0.60
c1	0.33	0.63
D2	8.20	9.20
E	9.60	10.50
e	2.39	2.69
F	1.20	1.35
L	13.11	14.61
L2	3.55	4.05
Q	1.10	1.40
Q1	2.65	2.85



外形尺寸 PACKAGE MECHANICAL DATA

TO-263

单位 Unit: mm

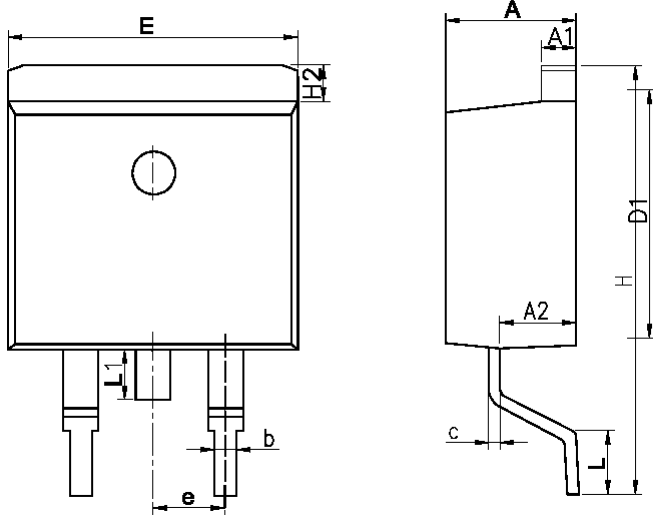

SYMBOL	MM	
	MIN	MAX
A	4.30	4.80
A1	1.12	1.42
A2	2.54	2.84
b	0.67	1.00
c	0.28	0.52
D1	8.40	9.00
E	9.80	10.46
e	2.54BSC	
H	14.00	16.00
H2	1.12	1.45
L	1.50	3.10
L1	1.45	1.70

编带 REEL

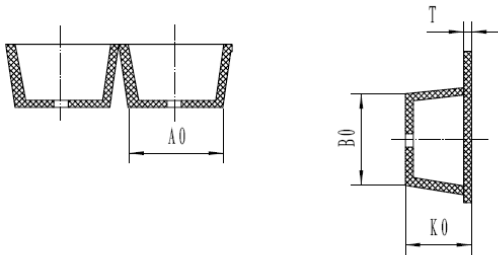
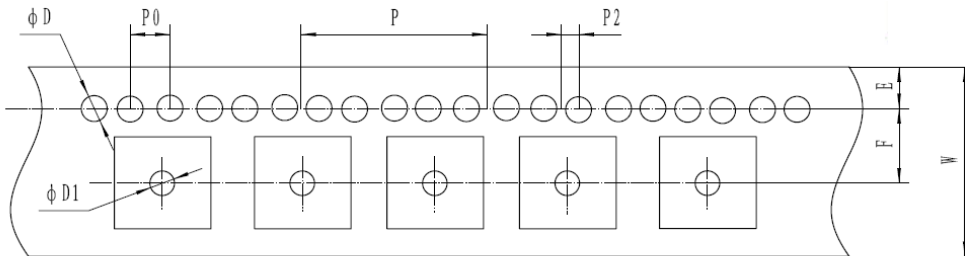

产品尺寸规格 (UNIT: mm)					
规格	W	A0	E	F	D
尺寸	24 ± 0.3	10.9 ± 0.1	1.75 ± 0.1	11.5 ± 0.1	1.5 + 0.1/-0
规格	D1	P0	P2	P	T
尺寸	1.5 + 0.1/-0	4 ± 0.1	2 ± 0.1	16 ± 0.1	0.35 ± 0.05
规格	K0	B0			
尺寸	4.9 ± 0.1	16.0 ± 0.1			