

JCS4N70C

主要参数 MAIN CHARACTERISTICS

I_D	4.0 A
V_{DSS}	700 V
$R_{Dson-max}$ (@ $V_{GS}=10V$)	2.8 Ω
Q_g-typ	16nC

用途

- 高频开关电源
- 电子镇流器
- UPS 电源

APPLICATIONS

- High frequency switching mode power supply
- Electronic ballast
- UPS

产品特性

- 低栅极电荷
- 低 C_{RSS} (典型值 14pF)
- 开关速度快
- 产品全部经过雪崩测试
- 高抗 dv/dt 能力
- RoHS 产品

FEATURES

- Low gate charge
- Low C_{RSS} (typical 14pF)
- Fast switching
- 100% avalanche tested
- Improved dv/dt capability
- RoHS product

封装 Package

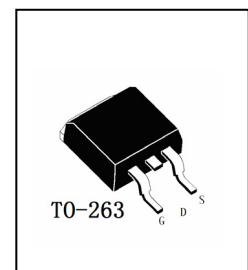
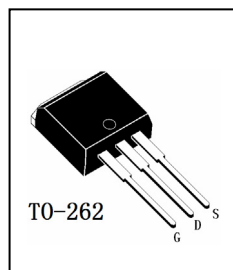
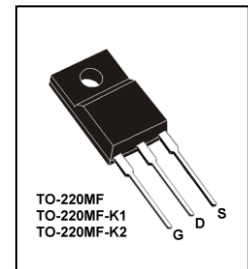
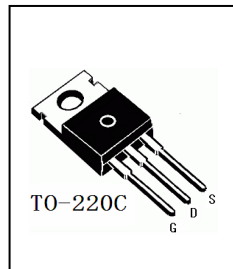
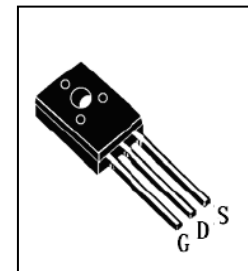
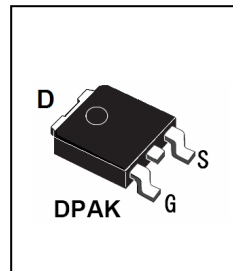
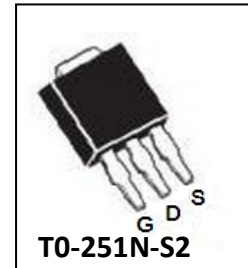
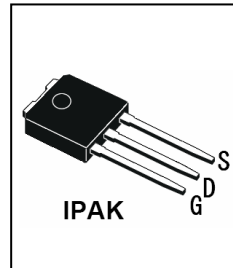
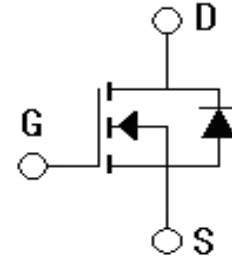

**订货信息 ORDER MESSAGE**

订货型号 Order codes	印记 Marking	封装 Package	无卤素 Halogen Free	包装 Packaging	器件重量 Device Weight
JCS4N70VC-O-V-N-B	JCS4N70V	IPAK	否 NO	条管 Tube	0.35 g(typ)
JCS4N70VC-R-V-N-B	JCS4N70V	IPAK	是 YES	条管 Tube	0.35 g(typ)
JCS4N70VC-R-VN2-N-B	JCS4N70V	TO-251N-S2	是 YES	条管 Tube	0.35 g(typ)
JCS4N70RC-O-R-N-B	JCS4N70R	DPAK	否 NO	条管 Tube	0.30 g(typ)
JCS4N70RC-O-R-N-A	JCS4N70R	DPAK	否 NO	编带 Reel	0.30 g(typ)
JCS4N70MFC-O-MF-N-B	JCS4N70MF	TO-126F	否 NO	条管 Tube	1.50 g(typ)
JCS4N70SC-O-S-N-B	JCS4N70S	TO-263	否 NO	条管 Tube	1.37 g(typ)
JCS4N70SC-O-S-N-A	JCS4N70S	TO-263	否 NO	编带 Reel	1.37 g(typ)
JCS4N70BC-O-B-N-B	JCS4N70B	TO-262	否 NO	条管 Tube	1.71 g(typ)
JCS4N70CC-O-C-N-B	JCS4N70C	TO-220C	否 NO	条管 Tube	2.15 g(typ)
JCS4N70FC-O-F-N-B	JCS4N70F	TO-220MF	否 NO	条管 Tube	2.20 g(typ)
JCS4N70FC-O-F1-N-B	JCS4N70F	TO-220MF-K1	否 NO	条管 Tube	1.78 g(typ)
JCS4N70FC-O-F2-N-B	JCS4N70F	TO-220MF-K2	否 NO	条管 Tube	1.78 g(typ)

绝对最大额定值 ABSOLUTE RATINGS (Tc=25℃)

项 目 Parameter	符 号 Symbol	数 值 Value				单 位 Unit
		JCS4N7 0MFC	JCS4N70V C/RC	JCS4N70S C/BC/CC	JCS4N70FC	
最高漏极—源极直流电压 Drain-Source Voltage	V _{DSS}	700				V
连续漏极电流 Drain Current -continuous	I _D T=25℃ T=100℃	4.0		4.0*		A
		2.5		2.5*		A
最大脉冲漏极电流 (注1) Drain Current - pulse (note 1)	I _{DM}	16		16*		A
最高栅源电压 Gate-Source Voltage	V _{GSS}	±30				V
单脉冲雪崩能量 (注2) Single Pulsed Avalanche Energy(note 2)	E _{AS}	265				mJ
雪崩电流 (注1) Avalanche Current (note 1)	I _{AR}	4.0				A
重复雪崩能量 (注1) Repetitive Avalanche Current (note 1)	E _{AR}	11.0				mJ
二极管反向恢复最大电压 变化速率 (注3) Peak Diode Recovery dv/dt (note 3)	dv/dt	5.0				V/n s
耗散功率 Power Dissipation	P _D T _C =25℃ -Derate above25℃	26	51	100	33	W
		0.21	0.39	0.80	0.26	W/ ℃
最高结温及存储温度 Operating and Storage Temperature Range	T _J , T _{STG}	-55~+150				℃
引线最高焊接温度 Maximum Lead Temperature for Soldering Purposes	T _L	300				℃

*漏极电流由最高结温限制

*Drain current limited by maximum junction temperature

电特性 ELECTRICAL CHARACTERISTICS

项 目 Parameter	符 号 Symbol	测试条件 Tests conditions	最小 Min	典型 Typ	最大 Max	单位 Units
关态特性 Off –Characteristics						
漏—源击穿电压 Drain-Source Voltage	BV_{DSS}	$I_D=250\mu A, V_{GS}=0V$	700	-	-	V
击穿电压温度特性 Breakdown Voltage Temperature Coefficient	$\Delta BV_{DSS}/\Delta T_J$	$I_D=250\mu A$, referenced to $25^\circ C$	-	0.66	-	V/ $^\circ C$
零栅压下漏极漏电流 Zero Gate Voltage Drain Current	I_{DSS}	$V_{DS}=700V, V_{GS}=0V,$ $T_C=25^\circ C$	-	-	10	μA
		$V_{DS}=560V, T_C=125^\circ C$	-	-	100	μA
正向栅极体漏电流 Gate-body leakage current, forward	I_{GSSF}	$V_{DS}=0V, V_{GS}=30V$	-	-	100	nA
反向栅极体漏电流 Gate-body leakage current, reverse	I_{GSSR}	$V_{DS}=0V, V_{GS}=-30V$	-	-	-100	nA
通态特性 On-Characteristics						
阈值电压 Gate Threshold Voltage	$V_{GS(th)}$	$V_{DS} = V_{GS}, I_D=250\mu A$	2.0	-	4.0	V
静态导通电阻 Static Drain-Source On-Resistance	$R_{DS(ON)}$	$V_{GS} = 10V, I_D=2A$	-	2.6	2.8	Ω
正向跨导 Forward Transconductance	g_{fs}	$V_{DS} = 40V, I_D=2A$ (note 4)	-	3.6	-	S
动态特性 Dynamic Characteristics						
输入电容 Input capacitance	C_{iss}	$V_{DS}=25V,$ $V_{GS}=0V,$ $f=1.0MHz$	-	790	950	pF
输出电容 Output capacitance	C_{oss}		-	67	92	pF
反向传输电容 Reverse transfer capacitance	C_{rss}		-	14	17	pF

电特性 ELECTRICAL CHARACTERISTICS

开关特性 Switching Characteristics						
延迟时间 Turn-On delay time	$t_{d(on)}$	$V_{DD}=350V, I_D=4A, R_G=25\Omega$ (note 4, 5)	-	30	50	ns
上升时间 Turn-On rise time	t_r		-	65	110	ns
延迟时间 Turn-Off delay time	$t_{d(off)}$		-	50	130	ns
下降时间 Turn-Off Fall time	t_f		-	45	90	ns
栅极电荷总量 Total Gate Charge	Q_g	$V_{DS}=560V,$ $I_D=4A$ $V_{GS}=10V$ (note 4, 5)	-	16	20	nC
栅-源电荷 Gate-Source charge	Q_{gs}		-	2.0	-	nC
栅-漏电荷 Gate-Drain charge	Q_{gd}		-	7.0	-	nC
漏-源二极管特性及最大额定值 Drain-Source Diode Characteristics and Maximum Ratings						
正向最大连续电流 Maximum Continuous Drain-Source Diode Forward Current		I_S	-	-	4	A
正向最大脉冲电流 Maximum Pulsed Drain-Source Diode Forward Current		I_{SM}	-	-	16	A
正向压降 Drain-Source Diode Forward Voltage	V_{SD}	$V_{GS}=0V,$ $I_S=4.0A$	-	-	1.4	V
反向恢复时间 Reverse recovery time	t_{rr}	$V_{GS}=0V, I_S=4.0A$ $di_F/dt=100A/\mu s$ (note 4)	-	340	-	ns
反向恢复电荷 Reverse recovery charge	Q_{rr}		-	2.65	-	μC

热特性 THERMAL CHARACTERISTIC

项 目 Parameter	符 号 Symbol	最大 Max				单 位 Unit
		JCS4N7 0MFC	JCS4N7 0VC/RC	JCS4N70 SC/BC/CC	JCS4N70 FC	
结到管壳的热阻 Thermal Resistance, Junction to Case	$R_{th(j-c)}$	4.8	2.50	1.25	3.79	$^{\circ}C/W$
结到环境的热阻 Thermal Resistance, Junction to Ambient	$R_{th(j-A)}$	110	83	62.5	62.5	$^{\circ}C/W$

注释:

- 1: 脉冲宽度由最高结温限制
- 2: $L=31mH, I_{AS}=4.0A, V_{DD}=50V, R_G=25\Omega$, 起始结温 $T_J=25^{\circ}C$
- 3: $I_{SD} \leq 4.0A, di/dt \leq 200A/\mu s, V_{DD} \leq BV_{DSS}$, 起始结温 $T_J=25^{\circ}C$
- 4: 脉冲测试: 脉冲宽度 $\leq 300\mu s$, 占空比 $\leq 2\%$
- 5: 基本与工作温度无关

Notes:

- 1: Pulse width limited by maximum junction temperature
- 2: $L=31mH, I_{AS}=4.0A, V_{DD}=50V, R_G=25\Omega$, Starting $T_J=25^{\circ}C$
- 3: $I_{SD} \leq 4.0A, di/dt \leq 200A/\mu s, V_{DD} \leq BV_{DSS}$, Starting $T_J=25^{\circ}C$
- 4: Pulse Test: Pulse Width $\leq 300\mu s$, Duty Cycle $\leq 2\%$
- 5: Essentially independent of operating temperature

特征曲线 ELECTRICAL CHARACTERISTICS (curves)

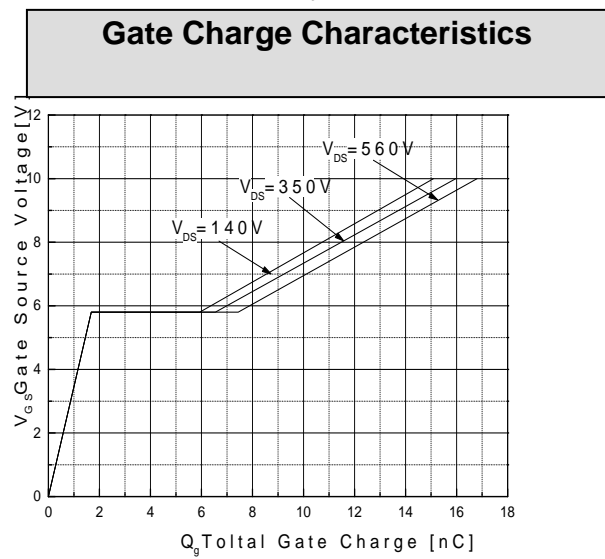
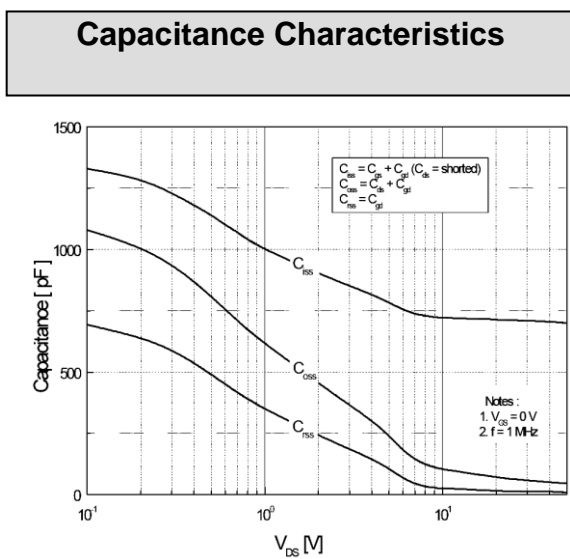
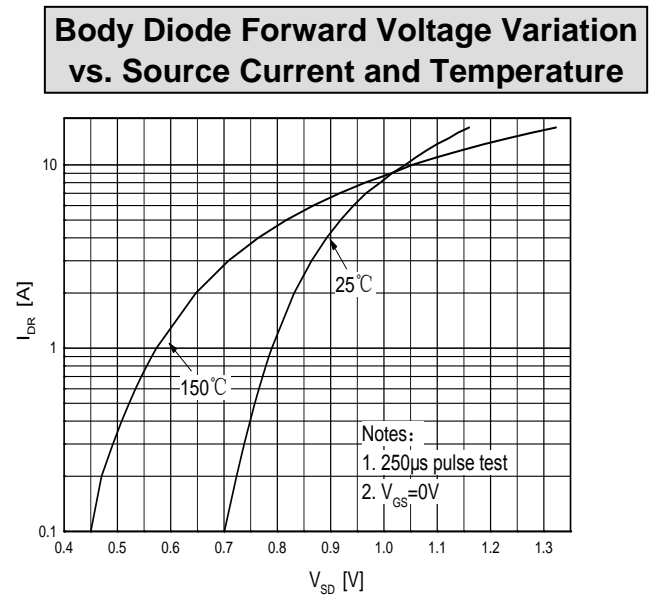
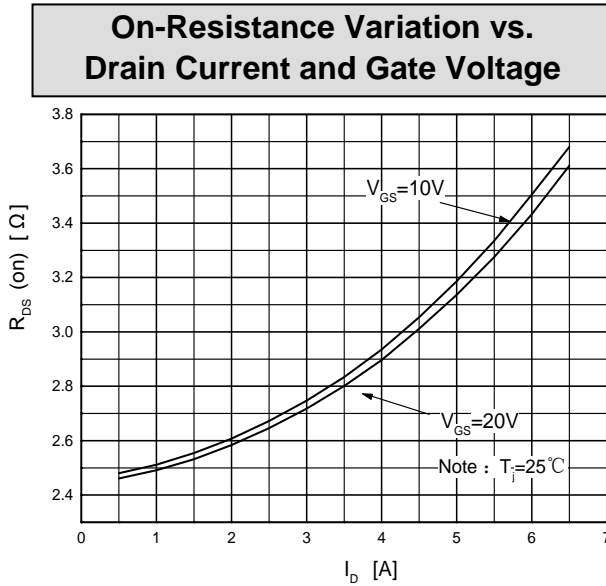
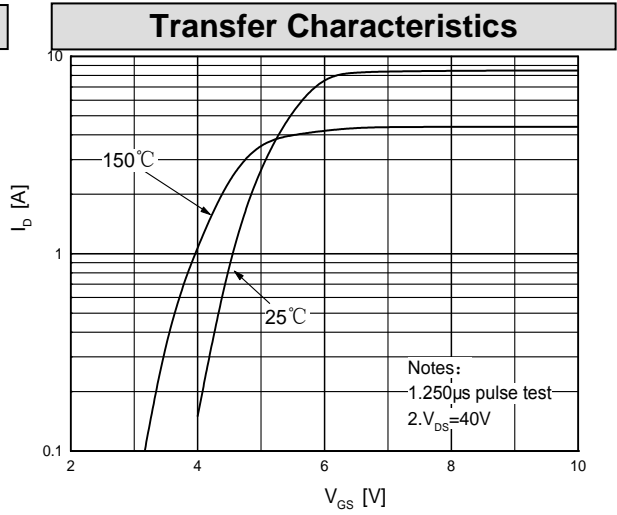
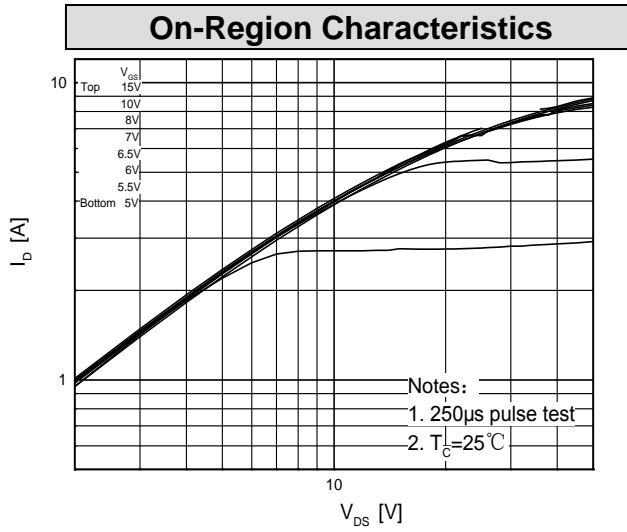

特征曲线 ELECTRICAL CHARACTERISTICS (curves)

Breakdown Voltage Variation vs. Temperature

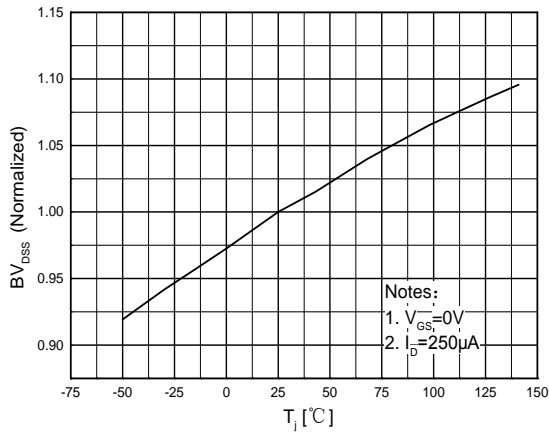

On-Resistance Variation vs. Temperature

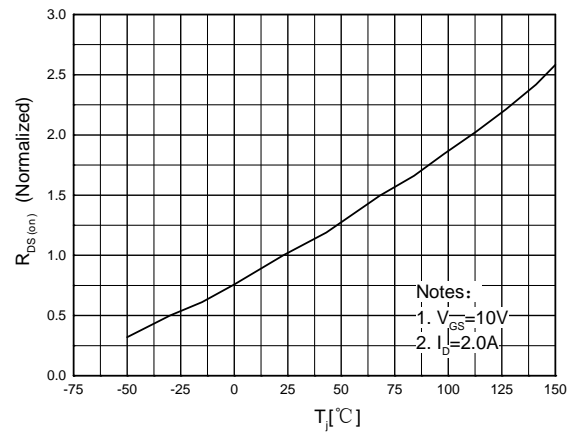

Maximum Safe Operating Area For JCS4N70VC/RC/SC/BC/CC

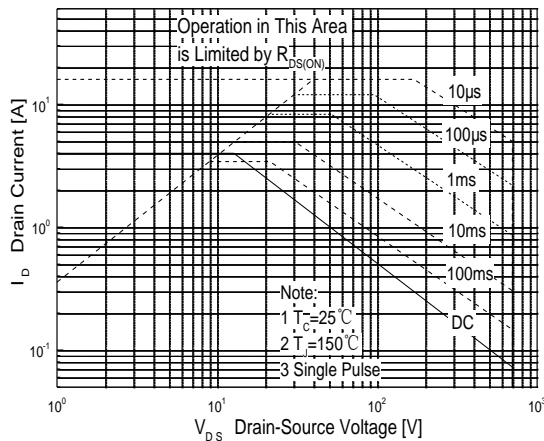

Maximum Safe Operating Area For JCS4N70FC

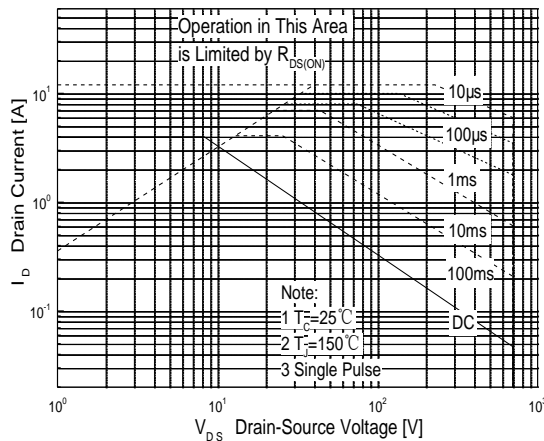

Maximum Drain Current vs. Case Temperature

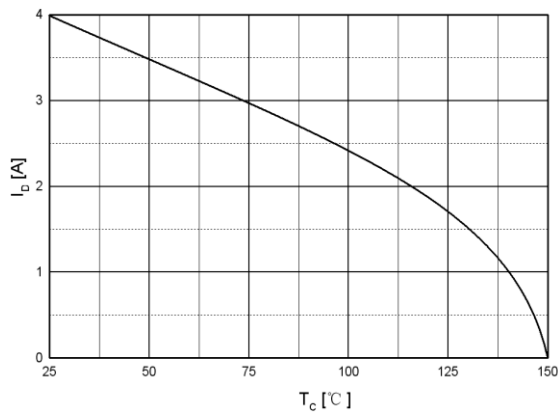

特征曲线 ELECTRICAL CHARACTERISTICS (curves)

**Transient Thermal Response Curve
For JCS4N70VC/RC**

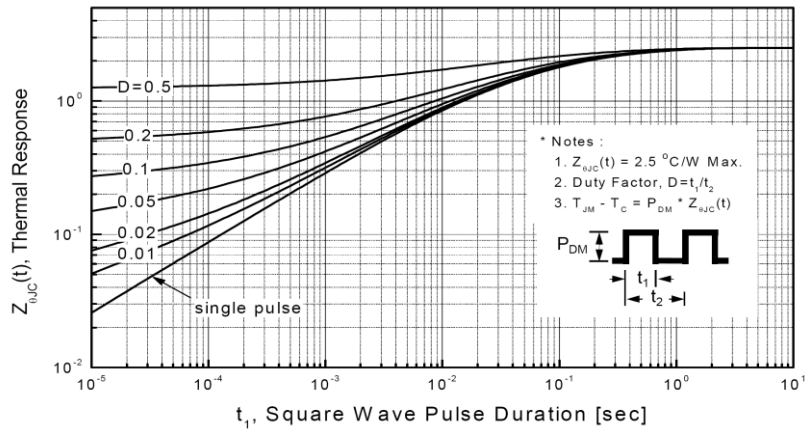

**Transient Thermal Response Curve
For JCS4N70SC/BC/CC**

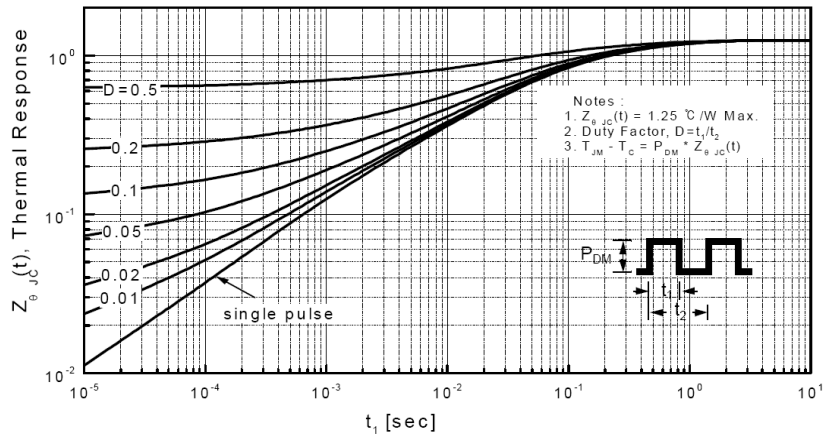

**Transient Thermal Response Curve
For JCS4N70FC**

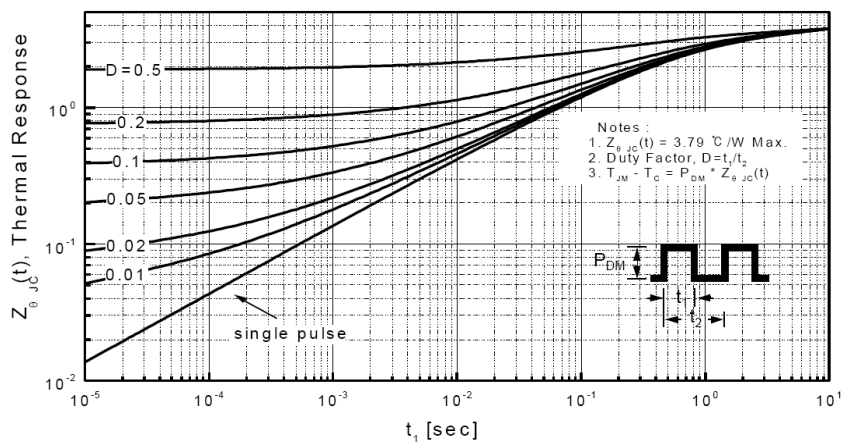

外形尺寸 PACKAGE MECHANICAL DATA

TO-126F

单位 Unit: mm

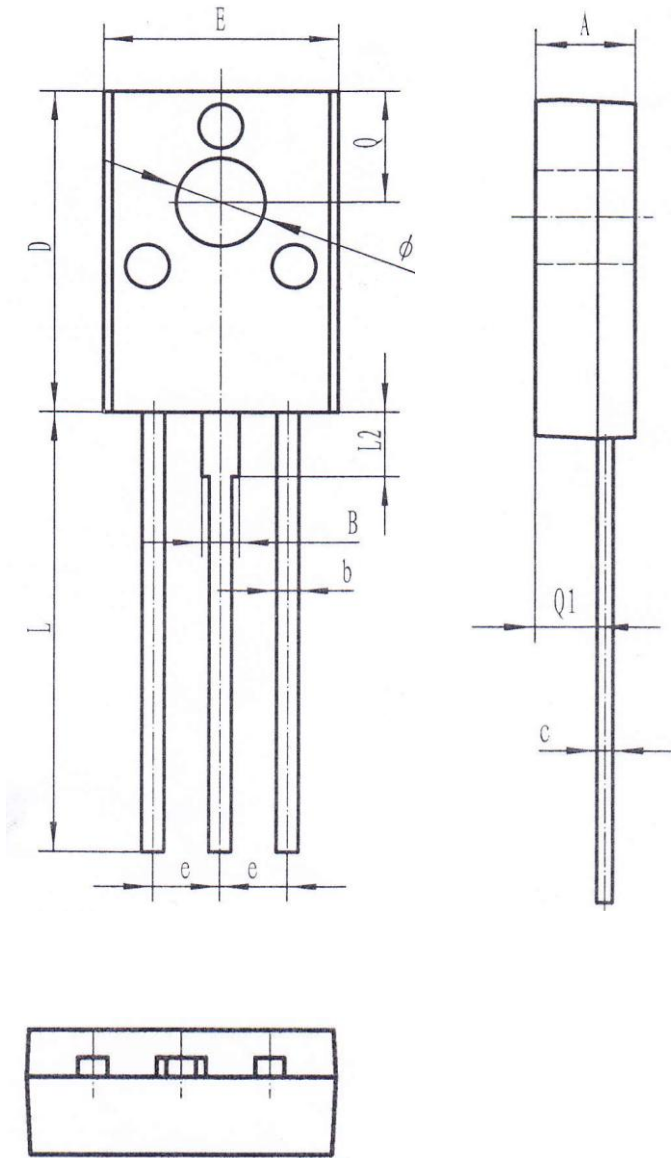

符号 symbol	MIN	MAX
A	3.10	3.30
B	1.22	1.47
b	0.60	0.90
c	0.45	0.70
D	10.50	11.20
E	7.50	8.50
e	2.29 TYP	
L	15.00	16.00
L2	2.10	2.30
Q	3.60	4.00
Q1	1.80	2.20
P	2.95	3.15

外形尺寸 PACKAGE MECHANICAL DATA

IPAK

单位 Unit: mm

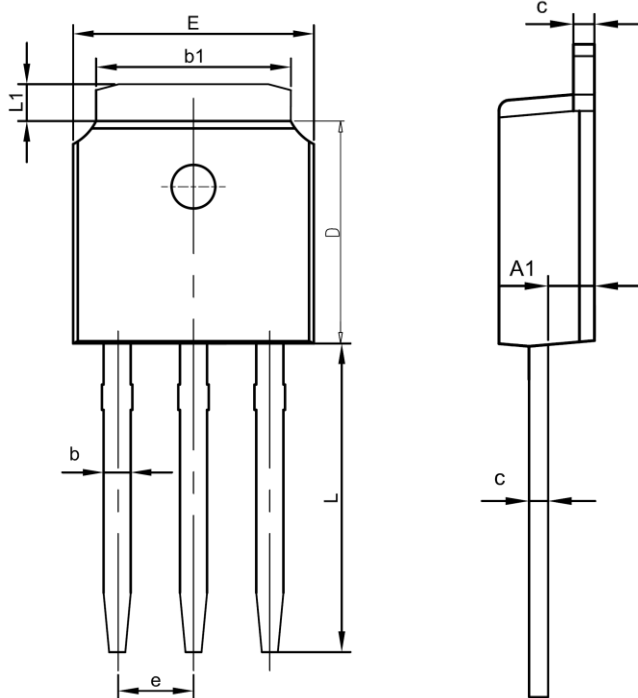

SYMBOL	MM	
	MIN	MAX
A	2.1	2.5
A1	0.87	1.27
b	0.63	0.93
b1	5.13	5.53
c	0.40	0.60
D	5.80	6.40
E	6.30	6.90
L	9.10	9.70
e	2.286BSC	
L1	0.82	1.22

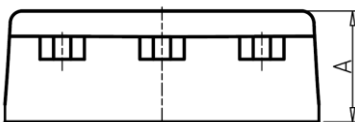

外形尺寸 PACKAGE MECHANICAL DATA

TO-251N-S2

单位 Unit: mm

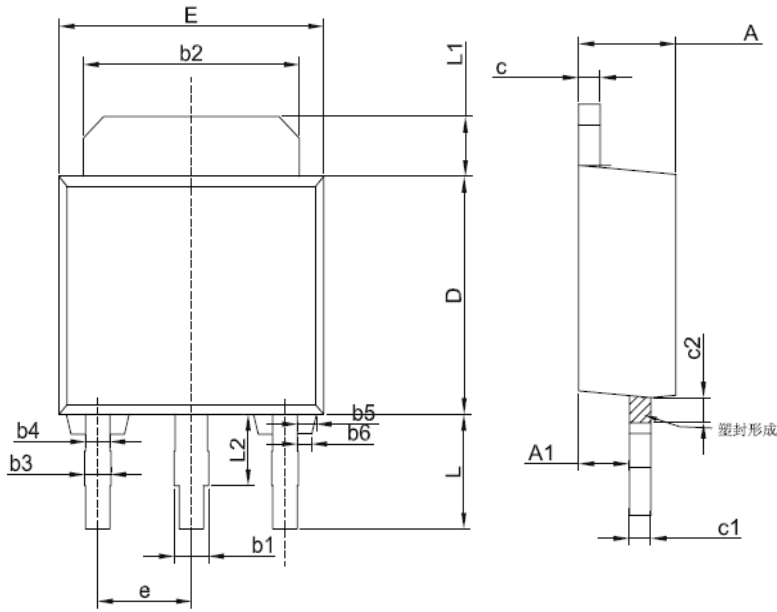

SYMBOL	MM	
	MIN	MAX
A	2.050	2.550
A1	1.050	1.350
b1	0.680	0.920
b2	5.150	5.450
b3	0.530	0.770
b4	0.480	0.720
b5	0.280	0.520
b6	0.180	0.420
c	0.400	0.600
c1	0.400	0.600
c2	0.180	0.420
D	5.350	5.850
E	6.350	6.850
e	2.3 (TYP)	
L	2.550	3.050
L1	1.4	1.8
L2	1.25	1.55

外形尺寸 PACKAGE MECHANICAL DATA

DPAK

单位 Unit: mm

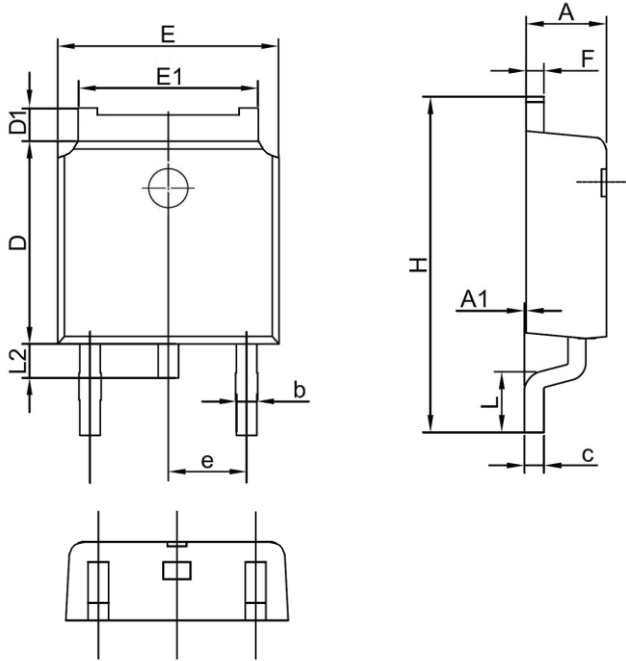

符号 symbol	MIN	MAX
A	2.2	2.4
A1	0.0	0.2
b	0.7	0.9
c	0.45	0.55
D	6.0	6.3
D1	0.8	1.2
E	6.5	6.8
E1	5.2	5.5
e	2.28TYP	
F	0.45	0.55
H	9.65	10.45
L	1.4	1.7
L2	0.6	1.0

编带 REEL

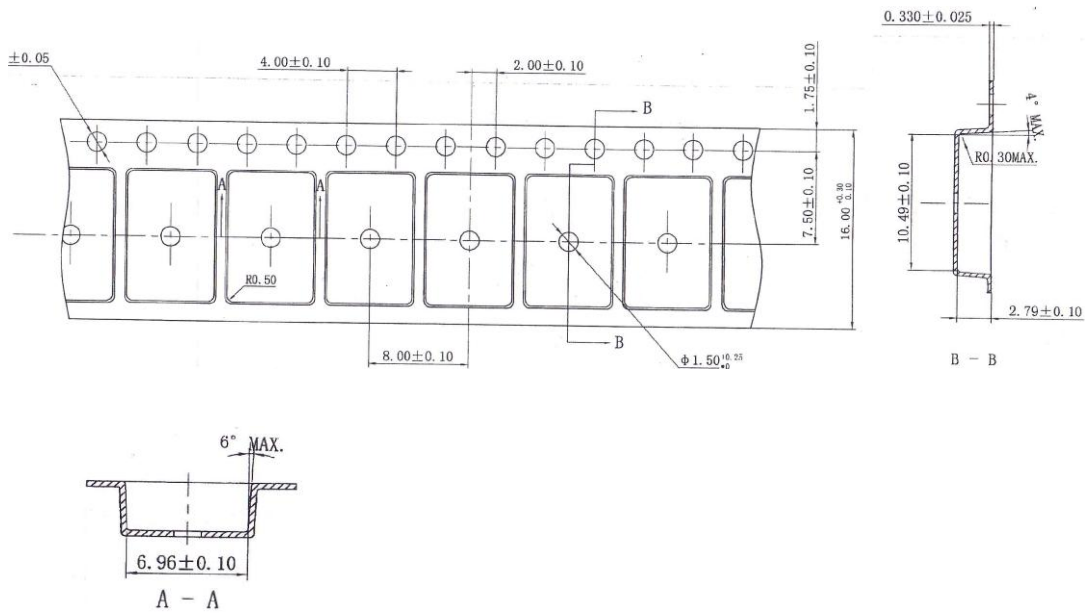

外形尺寸 PACKAGE MECHANICAL DATA

TO-262

单位 Unit: mm

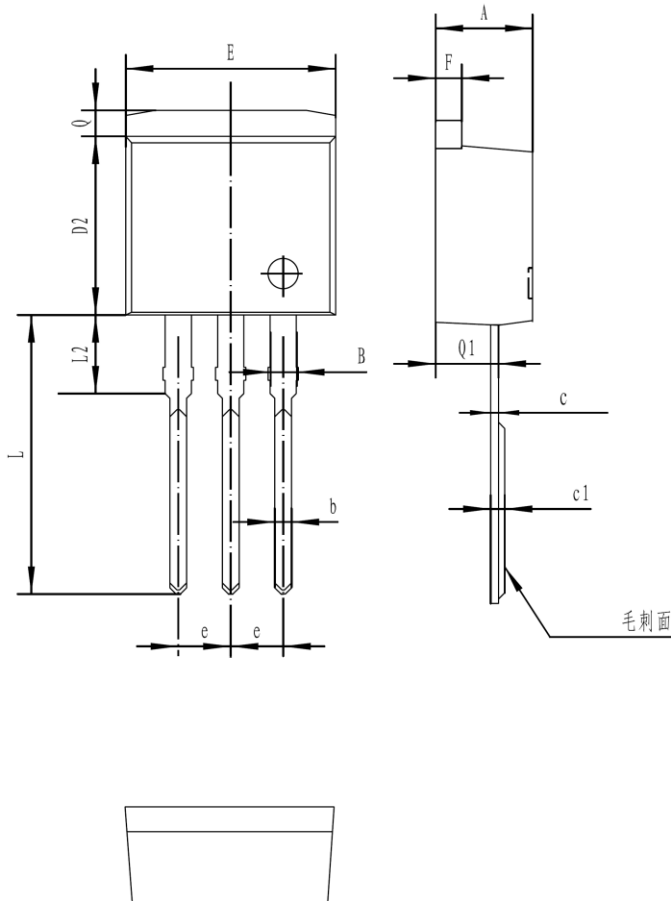

符号 symbol	MIN	MAX
A	4.40	4.90
B	1.10	1.40
b	0.70	0.95
c	0.30	0.60
c1	0.33	0.63
D2	8.20	9.20
E	9.60	10.50
e	2.39	2.69
F	1.20	1.35
L	13.11	14.61
L2	3.55	4.05
Q	1.10	1.40
Q1	2.65	2.85

外形尺寸 PACKAGE MECHANICAL DATA

TO-263

单位 Unit: mm

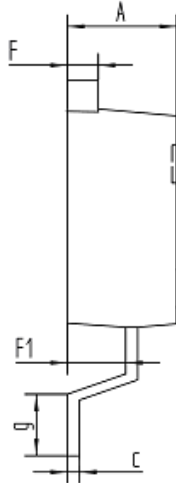
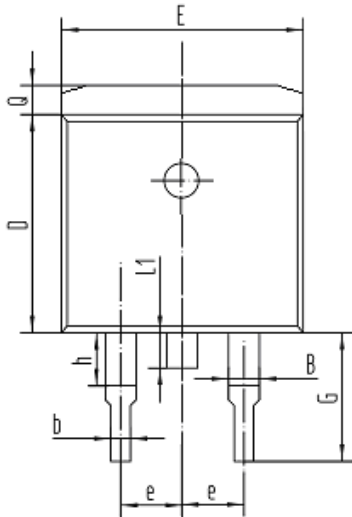

符合 symbol	MIN	MAX
A	4.3	4.8
B	1.2	1.4
D	8.5	8.8
E	9.5	10.5
F	1.2	1.4
F1	2.5	2.9
G	4.7	5.5
L1	1.4	1.7
Q	1.2	1.5
b	0.75	0.95
c	0.35	0.5
e	2.49	2.59
g	1.9	2.7
h	2.3	3.3

编带 REEL

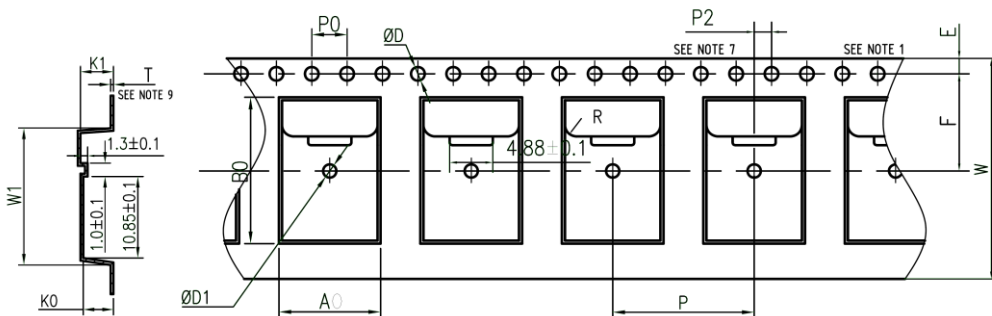

NOTES

- 10 SPROCKET HOLE PITCH CUMULATIVE TOLERANCE 0.2mm;
任意10个传输孔间距累积误差0.2mm;
- MATERIAL: BLACK CONDUCTIVE POLYSTYRENE;
材料: 黑色防静电聚苯乙烯;
- DIMENSIONS ARE IN mm (UNLESS OTHERWISE SPECIFIED);
除非特别标注, 尺寸单位为毫米;
- K0 MEASURED FROM A PLANE ON THE INSIDE BOTTOM OF THE POCKET TO THE TOP SURFACE ON THE CARRIER;
K0是从凹槽底部上表面到载带顶面的测量尺寸;
- A0 AND B0 MEASURED ON A PLANE 0.30mm ABOVE THE BOTTOM OF THE POCKET;
从凹槽底部上方测量A0和B0的平面度是0.30mm;
- SURFACE RESISTIVITY IS BETWEEN 1×10^6 TO 1×10^{10} OHMS/SQUARE;
表面电阻 $1 \times 10^6 \sim 1 \times 10^{10} \Omega/\square$;
- Allowable Camber to be 1 mm/100 mm
载带100mm以内, 弯曲度不可超过1mm。

外观	尺寸	外观	尺寸
P0	4.0 ± 0.1	W	24.0 ± 0.3
P2	2.0 ± 0.1	A0	10.8 ± 0.2
P	16.0 ± 0.1	E	1.75 ± 0.1
T	0.35 ± 0.05	F	11.5 ± 0.1
K0	4.85 ± 0.1	D	1.55 ± 0.05
B0	16.3 ± 0.1	D1	1.5 ± 0.1
W1	规格1	规格1	16.9 ± 0.1
	规格2	规格2	17.2 ± 0.1

外形尺寸 PACKAGE MECHANICAL DATA

TO-220C

单位 Unit: mm

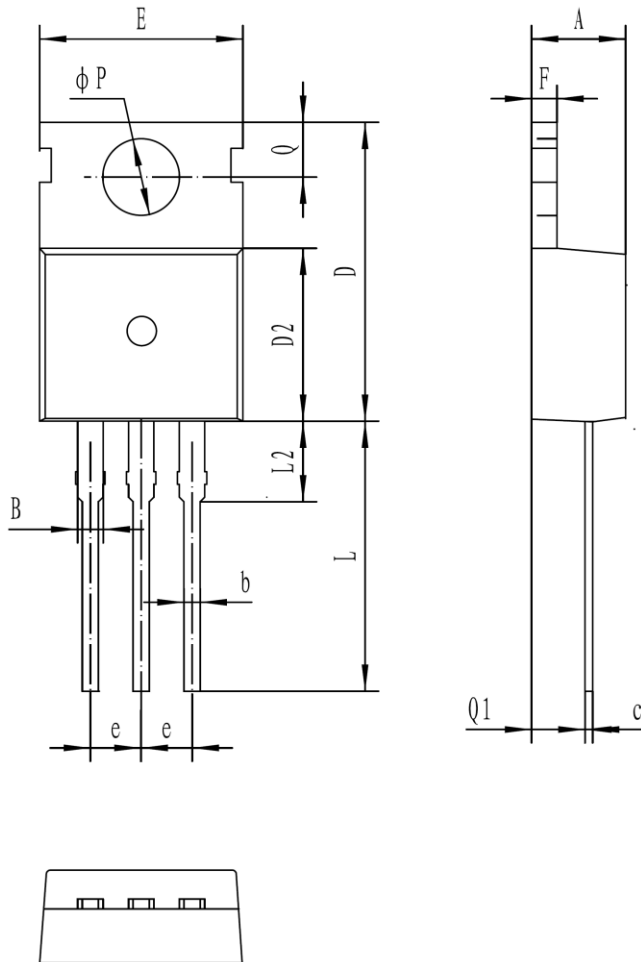

符号 symbol	MIN	MAX
A	4.30	4.70
B	1.10	1.40
b	0.70	0.95
c	0.40	0.65
D	15.20	16.20
D2	9.00	9.40
E	9.70	10.10
e	2.39	2.69
F	1.25	1.40
L	12.60	13.60
L2	2.80	3.20
Q	2.60	3.00
Q1	2.20	2.60
P	3.50	3.80

外形尺寸 PACKAGE MECHANICAL DATA

TO-220MF

单位 Unit: mm

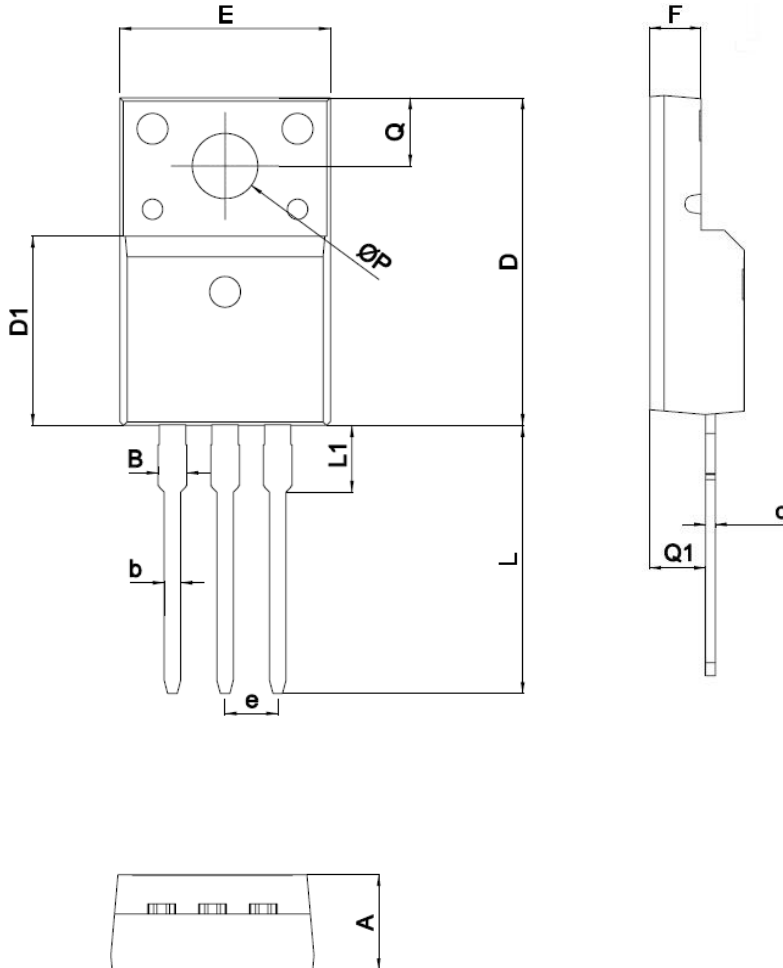

SYMBOL	mm	
	MIN	MAX
A	4.5	4.9
B		1.47
b	0.7	0.9
c	0.45	0.60
D	15.67	16.07
D1	9.04	9.20
e	2.54TYPE	
E	9.96	10.36
F	2.34	2.74
L	12.58	13.38
L1	3.13	3.33
Q	3.2	3.4
Q1	2.56	2.96
ΦP	3.08	3.28

外形尺寸 PACKAGE MECHANICAL DATA

TO-220MF-K1

单位 Unit: mm

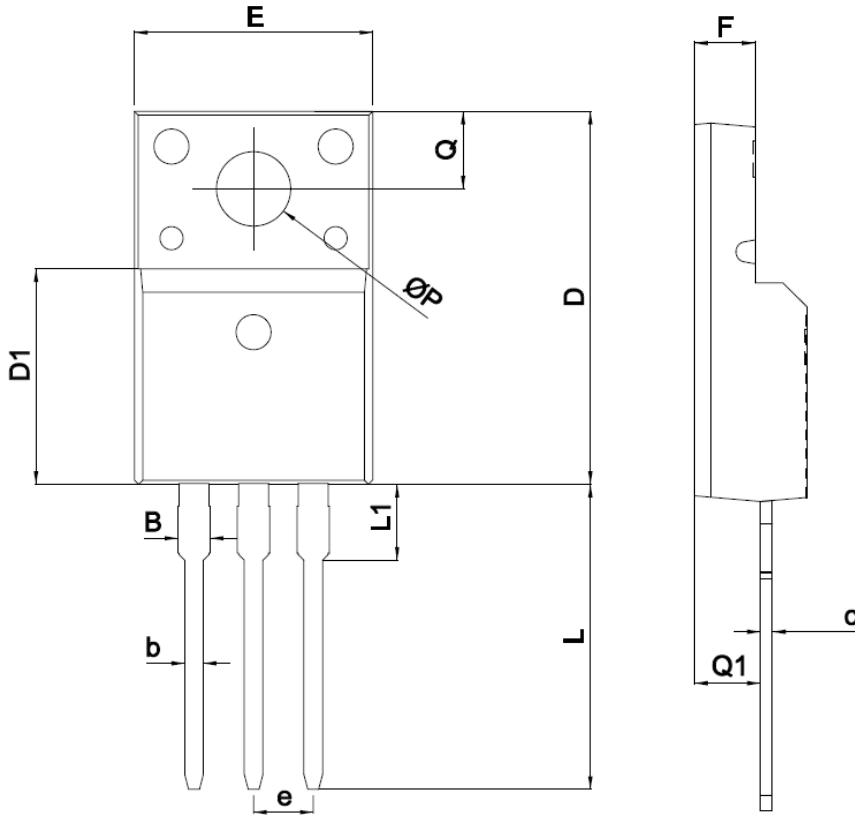

SYMBOL	mm	
	MIN	MAX
A	4.5	4.9
B	1.22	1.47
b	0.7	0.9
c	0.45	0.60
D	15.6	16.1
D1	9.0	9.3
e	2.54TYPE	
E	9.9	10.4
F	2.3	2.8
L	12.6	13.3
L1	3.1	3.4
Q	3.2	3.4
Q1	2.6	2.9
ΦP	3.0	3.5

外形尺寸 PACKAGE MECHANICAL DATA

TO-220MF-K2

单位 Unit: mm

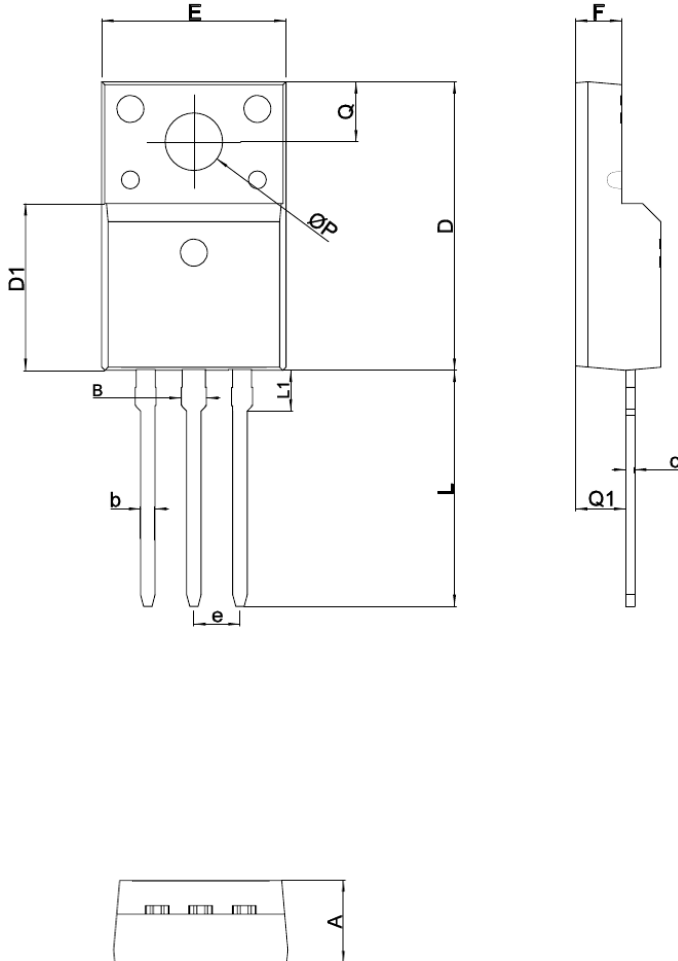

SYMBOL	mm	
	MIN	MAX
A	4.5	4.9
B		1.27
b	0.59	0.79
c	0.45	0.60
D	15.67	16.07
D1	8.97	9.37
e	2.54TYPE	
E	9.96	10.36
F	2.34	2.74
L	12.65	13.35
L1	1.80	2.20
Q	3.2	3.4
Q1	2.56	2.96
ΦP	3.08	3.28